

**piranha**  
OFF ROAD PRODUCTS

# Dual Battery Cradle Fitting Instructions



**AFTERMART**  
WHOLESALE  
QUALITY VEHICLE ACCESSORIES

## CONDITIONS OF SALE

To obtain full Piranha warranty the battery cradle must be installed by an authorised Piranha installer. All the correct mounting brackets must be used in the appropriate positioning. No modifications may be made to the cradle. If other under bonnet components are in the way they must be relocated by personnel who are qualified to do the modifications. ie. Air conditioner pipes - the system may have to be degassed, the pipe modified or remounted so as not to interfere with the dual battery instruction.

The Piranha warranty covers only the products manufactured by Piranha. It is in no way to be construed that we cover any consequential damage. We will repair or in most cases replace any faulty part at no charge, but we do not pay for fitting/recovery/towing or any other related expense.

If a product has been self fitted, you may still have full warranty but only if the fitting work is up to Piranha standard. This can be verified by having the installation checked by Piranha or one of its agents. This can be proved in writing.

THESE BATTERY CRADLES ARE DESIGNED FOR AUTOMOTIVE TYPE BATTERIES NOT MARINE OR SPECIAL USE DESIGNS. IT IS THE RESPONSIBILITY OF THE FITTER TO ENSURE ADEQUATE SAFE CLEARANCES.

## CONDITIONS OF WARRANTY

1. Piranha warrants the product against faulty manufacture for a period of 2 years from the date of purchase.
2. The warranty is on the product only.
3. Piranha will replace or repair the faulty item - we do not pay for consequential damage, towing, labour etc.
4. Piranha retains full title of the product until it is paid for in full.
5. To obtain warranty it is the responsibility of the customer to return the product to us.
6. Piranha will pay for freight out but not freight in with regard to warranty.
7. Piranha is not responsible for any stock that is lost or damaged in transit.
8. Any goods specifically ordered in may not be returned.
9. Any invoice under \$100.00 incurs a \$3.00 handling fee.
10. A handling fee for goods returned will apply.

## KEY TO FITTING GUIDE SYMBOLS



### APPROVED FOR SELF FIT

Piranha approve of this tray to be self fit. It replaces or is easily fit with existing cradle.

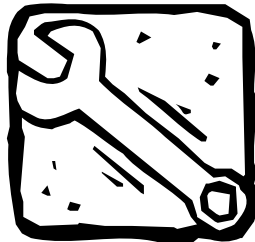

### NOT SUITABLE FOR SELF FIT

Piranha do not recommend this tray to be sold for home fitting.

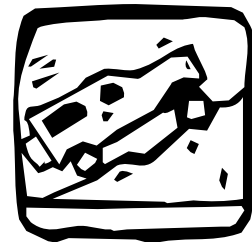

### NOT SUITABLE FOR SEVERE SERVICE

Piranha do not recommend this tray to be sold for severe service.

**DS = Drivers side, PS = Passenger side, R = Rear, M = Middle, F = Front, T = Twin**

Produced by Baron Printing Melbourne for  
PIRANHA OFF ROAD PRODUCTS

© Piranha 2007  
REPRINT CODE: PIRFIT102000

# Contents at a Glance

Conditions of Sale / Key to Fitting Guide Symbols

4 / 5

**CONTENTS AT A GLANCE**

1 / 2 / 3

FACTS ABOUT BATTERIES AND DUAL BATTERY SYSTEMS

6

## FITTING INSTRUCTIONS BY: SECTION / MANUFACTURE / MODEL / PART NUMBER

### SECTION ONE:

### PAGE:

#### TOYOTA

LANDCRUISER	FJ40/BJ40	BT40S	7
LANDCRUISER	FJ40/BJ40/HJ47	BT40D	7
LANDCRUISER	FJ55	BT55	7
LANDCRUISER	60	BT60	7
BUNDERA	70	BT70	8
LANDCRUISER	70 SERIES	BT70V8D	8
LANDCRUISER	70 SERIES	BT70V8DO	8
LANDCRUISER	HZJ75	BT75R	8
LANDCRUISER	HJ75	BT75M	9
LANDCRUISER	HZJ75(TROOP/UTE)	BT75DR	9
LANDCRUISER	HZJ75	BT75D/BT78D	9
LANDCRUISER	HZJ78	BT78R/79R	9
LANDCRUISER	80DIESEL	BT80D	10
LANDCRUISER	80EFI	BT80PE	10
LANDCRUISER	80CARBY	BT80PO	10
LANDCRUISER	80TWIN CAM	BT80TC	10
LANDCRUISER	100	BT100	11
LANDCRUISER	100 3rd Tray	BT100R	11
LANDCRUISER	100 Series V8	BT100V8	11
LANDCRUISER	200 SERIES V8 D	BT200V8D	11
LANDCRUISER	200 SERIES V8 D	BT200PV8	12
LANDCRUISER	200 SERIES V8 D	BT200V8DRD	12
LANDCRUISER	200 SERIES V8 D	BT200V8DRP	12
LEXUS	V8	BTLEXUS	12
PRADO	DIESEL	BTPRAD	13
PRADO	4CYL/V6 non ABS	BTPRA4C	13
PRADO	4CYL/V6 Replacement	BTPRA4CO	13
PRADO	2003 DIESEL	BTPRAD03	13
PRADO	2003 PETROL	BTPRAP03	14
PRADO	2007 PETROL	BTPRAP07	14
HILUX	2.8 DIESEL	BTH2.8	14
HILUX	2.4 DIESEL	BTH2.4	14
4 RUNNER	V6	BT4R90	15
HILUX	3 DIESEL	BTH3	15
HILUX	3 TURBO DIESEL	BTT3LTD	15
HILUX	2.7EFI	BTH2.7	15
HILUX	3.4L V6 PETROL	BTPRA4C	16
HILUX	4 Cyl Petrol	BTPRA4C0	16
HILUX	2005 DIESEL V6	BTH05	16

# Contents at a Glance

FITTING INSTRUCTIONS BY: SECTION / MANUFACTURE / MODEL / PART NUMBER

## SECTION TWO:

PAGE:

### NISSAN

PATROL	MK-MQ	BTMQD	16
PATROL	MK-MQ	BTMQP	17
PATROL	GQ DIESEL	BTGQD	17
PATROL	GQ2.8 TURB/SNORKEL	BTGQ2.8	17
PATROL	GQ PETROL	BTGQP	17
PATROL	GU 4.5 EFI	BTGUP	18
PATROL	GU2.8 DIESEL	BTGU2.8D	18
PATROL	GU 4.8L PETROL	BTGU4.8P	18
PATROL	GU 4.2 DIESEL+TURBO	BTGU4.2TD	18
PATROL	GU 3L & 4.2 TD Intercooled	BTGU4.2DI	19
PATROL	GU 4.5 SAFETY PACK		19
PATHFINDER	4 CYL	BTNP	19
PATHFINDER	V6	BTPF	20
PATHFINDER	McPHERSON STRUT	BTNPV6	20
PATHFINDER	V6 LARGE TRAY	BTPF8	20
PATHFINDER	2.5 TDI	BTPF06	20
NAVARA	PETROL	BTNNP	21
NAVARA	DIESEL	BTNND	21
NAVARA	REAR	BTNNDR	21
NAVARA	D40 2.5L	BTPF06	21
TERRENO	PETROL	BTNTD	22
XTRAIL	PETROL	BTXTR	22

## SECTION THREE:

### MITSUBISHI

PAJERO	OLD	BTMPO	22
PAJERO	NEW	BTMPN	22
PAJERO	NEW	BTMPN10	23
PAJERO	NM	BTMPNM	23
TRITON	V6 OLD	BTMTP	23
TRITON	DIESEL	BTMTD	23
TRITON	2.8 DIESEL	BTMTP97/BTMT2.8	24
TRITON	2.8 L TDI	BTMT04	24
TRITON	ML DIESEL 2006	BTMTD06	24
TRITON	V6 EFI	BTMTV6	24
CHALLENGER	3L PETROL	BTMCH	25
CHALLENGER	2003 V6	BTMCH03	25

## SECTION FOUR:

### MAZDA

B2500	DIESEL	BTM25	25
2600(FORD COURIER)	CARBY	BTMBC	26
2600(FORD COURIER)	EFI	BTMBI	26
1999 MAZDA BRAVO	EFI	BTMR99	26
TDI		BTMTDI	26
MAZDA BT50	BT50TDI	BTMB50TDI	27
MAZDA BT50	BT50TDI AUTO	BTMB50TDIA	27
<b>THE ABOVE BT50 TRAYS ALSO FIT THE FORD RANGER</b>			
MAZDA	V6 EFI PETROL	BTMBV6P	27

# Contents at a Glance

FITTING INSTRUCTIONS BY: SECTION / MANUFACTURE / MODEL / PART NUMBER

			PAGE:
<b>FORD</b>			
F100/F150/BRONCO		BTF100	27
F250/BRONCO		BTF250	28
EXPLORER		BTFEX	28
<b>SECTION FIVE:</b>			
<b>HOLDEN</b>			
JACKAROO	OLD	BTHJO	28
JACKAROO	3.5 V6 PETROL	BTHJS	28
JACKAROO	3.5 V6 DIESEL	BTHJN	29
JACKAROO	99 DIESEL	BTHJ99D	29
RODEO	2.8 DIESEL	BTHRD	29
RODEO	2002	BTHRD02	29
RODEO	2003 P & D NON ABS	BTHRO3	30
RODEO	2006 DIESEL	BTHRD06	30
RODEO	2006 P Without ABS	BTHRP06/E	30
RODEO	2006 P with/out ABS	BTHRP06/O	30
RODEO	2007 RA 3L VCDI	BTHRD07	31
FRONTERA	4CYL	BTHF	31
FRONTERA	V6 PETROL	BTHFV6	31
<b>SECTION SIX:</b>			
<b>SUZUKI</b>			
SIERRA	1.0	BTSS	31
SIERRA	1.3	BTSS10	32
VITARA		BTSV	32
GRAND VITARA		BTSGV	32
JIMMY		BTSJI	32
<b>SECTION SEVEN:</b>			
<b>DAIHATSU</b>			
FEROZA		BTDF	33
ROCKY		BTDR	33
<b>SECTION EIGHT:</b>			
<b>JEEP</b>			
CHEROKEE SPORT	ORIG.	BTJCR	33
CHEROKEE SPORT	AUX.	BTJCA	33
GRAND		BTJCG	34
CHEROKEE	2.8 DIESEL	BTJKJD	34
<b>SECTION NINE:</b>			
<b>LAND ROVER</b>			
DEFENDER		BTDEF	34
DEFENDER	DURATECH ENGINE	BTDEFDT	34
TD5		BTTD5	35
TD5	DUAL AIR	BTTD5AC	35
TD6	V6 & TURBO DIESEL	BTTD6	35
<b>SECTION TEN:</b>			
<b>OTHER &amp; ACCESSORIES</b>			
KIA SPORTAGE		BTKIA	35
HYUNDI TERRACAN DIESEL		BHT05	36
ROCSTA DXL PETROL		BTROC	36
HUMMER H3		BTHUM3	36
SANGYONG MUSSO		BTMDDC	36

---

## FACTS ABOUT BATTERIES AND DUAL BATTERY SYSTEMS

Most people invest in a dual battery system as a safety precaution. It allows you to set up camp for the night and operate all your accessories from your auxiliary battery.

In this way you are relaxed in the knowledge that next morning your main battery will still be fully charged, ready to start your engine.

But there is a lot more to selecting a dual battery kit than most people realise in fact there are dozens of options. The option you require is dependant on your vehicle and how you use it.

That's why, when you see a Piranha dealer, before they even think of installing a kit, they ask you what you intend to use it for. Winching? Running accessories like fridges, lights and compressors? An emergency starting battery? Or a combination?

We also need to know some vital facts about your vehicle like petrol, EFI or diesel powered? And does the alternator have an internally or externally sensed regulator?

The answers you give dictate the Piranha system we recommend - the type of isolator, the way it's wired, even the type of battery and battery cradle.

In fact, each Piranha dual battery system is individually tailored to suit the needs of its owner.

Amazingly enough, a Piranha tailored solution usually costs no more than inferior makes..... In some cases, even less.

### BATTERY SPECIFICATIONS

#### CRANKING POWER

For many years the number of plates per cell was taken as a guide to the engine cranking power provided by the battery. However, over time this criteria proved to be misleading. Starting power is a function of the area of plate surface exposed to acid. If all plates were the same size (and therefore the same area) plates per cell would be a useful comparative guide. However, plate dimensions vary dramatically from one manufacturer to another. To overcome this difficulty, in 1985 the Australian battery manufacturers adopted the SAE (Society of Automotive Engineers) standard for cranking capability. Under the SAE standard, battery cranking power is specified in CCA's (cold cranking amps).

To make a valid comparison from one battery to another, it is absolutely vital for both battery performances to be quoted against the same standard test.

Performances quoted at higher temperatures, shorter durations or to higher end voltages, can be manipulated so as to appear superior to SAE ratings.

#### ACCESSORIES POWER

##### (AMP Hour Capacity)

The power available from a fully charged battery to operate accessories is a function of the weight of reactive lead contained on the battery plates, below the acid level. The weight of reactive material depends on the thickness of plates, area of plates below the acid level and the number of plates in each cell.

For many years the power available for accessories was quoted as 'amp hours'. In the case of automotive batteries, the amp hour rating was a statement of the amps that could be provided continuously for 20 hours. Whilst the amp hour rating did provide a rough guide to the weight of reactive lead available, it completely failed to indicate the ability of the battery to power the full vehicle accessory load. Some battery distributors use less severe tests conducted at higher temperatures to disguise low performance batteries. The Australian Standard specifies a standard measure for reserve capacity.

The reserve capacity rating for a battery is an attempt to specify in minutes how long a battery could keep the vehicle running in the case of a complete alternator failure with a notional level of accessories in use.

#### COLD CRANKING AMPS (CCA)

The international recognised battery performance test: the discharge load in amperes which a new fully charged battery at 18C (0F) can deliver for 30 seconds and maintain a voltage of 1.2 volts per cell or higher.

#### RESERVE CAPACITY (Minutes)

The time in minutes that a new fully charged battery will supply a constant load of 25 Amps at 25°C without the voltage falling below 10.5 volts for a 12 volt battery and 5.25 for 6 volt battery.

---



## LANDCRUISER 40 SERIES FJ40/BJ40

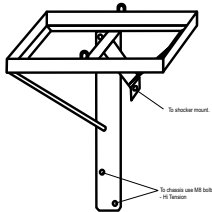

<b>PART NUMBER</b>	BT40S
<b>BATTERY SIZE</b>	12 inch - ED5
<b>APPROX. FITTING TIME</b>	1 hour
<b>INCLUDED</b>	2 X M8 Bolt Long 1 X Universal Top Mount 1 X Tray 2 X J Bolts
<b>LOCATION</b>	DSF

### FITTING INSTRUCTIONS

The cradle fits drivers side front corner.

This cradle is for SWB Landcruisers, usually 4 cylinder diesel, while most 6 cylinder models will take a dual cradle (BT40D). This is only chassis mounted (ie. not to body). Ensure all bolts are fitted and tight.

**NOTE: Can cause extreme damage if mounted to body at any point.**



## LANDCRUISER 40 SERIES FJ40/HJ40/HJ47 (DUAL CRADLE)

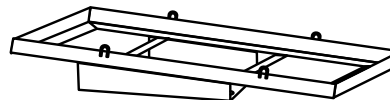
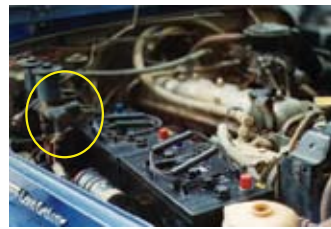

<b>PART NUMBER</b>	BT40D
<b>BATTERY SIZE</b>	12 inch X 2 - ED5
<b>APPROX. FITTING TIME</b>	2-3 hour
<b>INCLUDED</b>	1 X Tray 6 X M8 Bolt Long 2 X Universal Top Mount 4 X J Bolt
<b>LOCATION</b>	DSMT

### FITTING INSTRUCTIONS

The cradle fits on the drivers side middle replacing the existing tray.

Check to make sure that the original lower support bracket is in sound condition. If the bracket is cracked, fix it first before continuing with the cradle installation. The dual cradle utilises the original captive nuts in the lower bracket. Six M8 bolts hold the cradle in position. Sometimes the radiator support bracket has to be modified, so that the dual cradle can be installed. Two battery hold downs are provided.

**NOTE: Ensure adequate clearance to brake master cylinder.**



## LANDCRUISER 55 SERIES FJ55 6 Cyl Petrol

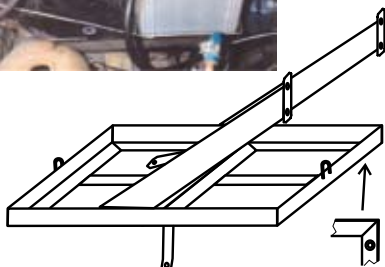

<b>PART NUMBER</b>	BT55
<b>BATTERY SIZE</b>	12 inch X 2 - ED5
<b>APPROX. FITTING TIME</b>	1 hour
<b>INCLUDED</b>	1 X M8 Bolt 1 X M8 Bolt (cnc sunk) 2 X M8 Nut 2 X M8 Washer 1 X Tray 4 X M8 Bolt Long 1 X Special Top Mount 2 X J Bolts
<b>LOCATION</b>	DSMT

### FITTING INSTRUCTIONS

The cradle fits drivers side middle and replaces original battery cradle.

**NOTE: Check clearance if old style air conditioning fitted. If there is damage to inner guard this must be repaired before fitting new cradle.**



## LANDCRUISER 60 SERIES 2F/3F PETROL & 2H/12HT TD

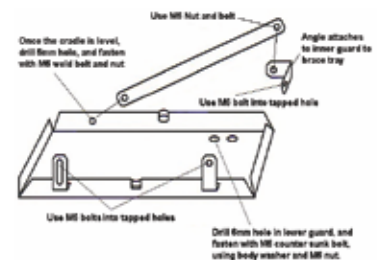

<b>PART NUMBER</b>	BT60
<b>BATTERY SIZE</b>	12 inch - ED 5
<b>APPROX. FITTING TIME</b>	1 hour
<b>INCLUDED</b>	2 X M8 Bolt 1 X M8 Bolt (cnc sunk) 3 X M8 Nut 1 X Body Washers 1 X Weld Bolt 1 X Tray 2 X M8 Bolt Long 1 X Universal Top Mount 2 X J Bolts 2 X Support arm brkts
<b>LOCATION</b>	PSF

### FITTING INSTRUCTIONS

The cradle fits passenger side front.

Remove radiator over-flow bottle and check that Air conditioning pipes are out of the way. Insert M8 bolt through the fixed hole in the bracket, then the other through the slot also using the long M8 bolt. Drill 6mm hole on guard and fasten with counter sunk M6 bolt using a washer and nut. After levelling the cradle, bolt the angle bracket into the tapped hole in the left guard, then attach the support arm. Nut and bolt support arm at the top. A 6mm hole needs to be drilled into the tray, this may need to be clamped when drilling the hole. Fasten with M6 weld bolt and nut. Relocate the over-flow bottle where convenient.

**NOTE: This tray can be used to replace original manufacturers cradle.**



**LANDCRUISER 70 SERIES**  
**BUNDERA 4cyl PETROL & 4cyl DIESEL**

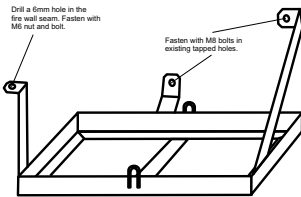

PART NUMBER
BT70
BATTERY SIZE
12 inch - ED5
APPROX. FITTING TIME
1 hour
INCLUDED
1 X Tray
1 X M8 Bolt
1 X M6 Nut
2 X M8 Bolt Long
1 X Universal Top Mount
2 X J Bolts
LOCATION
PSR

**FITTING INSTRUCTIONS**

The cradle fits passenger side rear.

The charcoal canister has to be lowered so that the cradle can be installed. Use two M8 bolts to fasten the cradle to the left hand guard, into original tapped holes. One 6mm hole must be drilled in the fire wall lip, and fasten the upper brace with an M6 nut and bolt.



**LANDCRUISER 70 SERIES**  
**4.5 L V8 TDI**



PART NUMBER
BT70V8D
BATTERY SIZE
12 inch HAZE Sealed
APPROX. FITTING TIME
1 hour
INCLUDED
1 X Tray
3 X M8 Bolt
3 X M6 Nut
3 X Body Washer
2 X M8 Body Short
1 X Universal Top Mount
2 X J Bolt
LOCATION
PSR

**FITTING INSTRUCTIONS**

The cradle fits passenger side rear.

The looms may have to be moved slightly, to ensure that they are not squashed. Bolt in top braces with M8 bolts. Then drill 6mm holes, where required and fasten with M6 bolts and nuts, using body washers under the guard.

No problems to fit.

**NOTE: This tray must only have a fully sealed battery installed, as acid leakage could damage computer loom**



**LANDCRUISER 70 SERIES**  
**4.5 L V8 TDI**



PART NUMBER
BT70V8DO
BATTERY SIZE
13 inch Optima
APPROX. FITTING TIME
1 hour
INCLUDED
1 X Tray
3 X M8 Bolt
3 X M6 Nut
3 X Body Washer
2 X M8 Body Short
1 X Universal Top Mount
2 X Long J Bolt
LOCATION
PSR

**FITTING INSTRUCTIONS**

The cradle fits passenger side rear.

The looms may have to be moved slightly, to ensure that they are not squashed. Bolt in top braces with M8 bolts. Then drill 6mm holes, where required and fasten with M6 bolts and nuts, using body washers under the guard.

No problems to fit.

**NOTE: This tray must only have a fully sealed battery installed, as acid leakage could damage computer loom**



**LANDCRUISER 75 SERIES**  
**1JZK/2JD & 3F/2F/ 4.5 L PETROL**

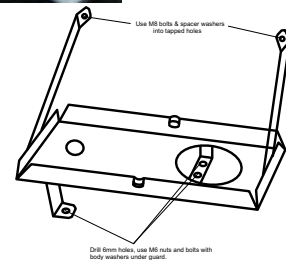

PART NUMBER
BT75R
BATTERY SIZE
12 inch - ED5
APPROX. FITTING TIME
½ hour
INCLUDED
1 X Tray
3 X M8 Bolt
3 X M6 Nut
3 X Body Washer
2 X Spacer Washer
2 X M8 Bolt Long
1 X Universal Top Mount
2 X J Bolts
LOCATION
PSR

**FITTING INSTRUCTIONS**

The cradle fits passenger side rear.

The looms may have to be moved slightly, to ensure that they are not squashed. Bolt in top braces with M8 bolts. Then drill 6mm holes, where required and fasten with M6 bolts and nuts, using body washers under the guard.

No problems to fit.

**NOTE: This tray can be used to replace original manufacturers cradle.**





**LANDCRUISER 75 SERIES**  
HJ75 3.4L D/TD 3F PETROL (Mid Mount)



PART NUMBER	FITTING INSTRUCTIONS
BT75M	The cradle fits passenger side middle in front of original battery.
<b>BATTERY SIZE</b>	
12 inch - ED5	Existing looms will have to be relocated, so they fit under the battery tray, ensuring that they are not squashed. Two earth wires may also have to be relocated, as well as a vacuum sensor.
<b>APPROX. FITTING TIME</b>	
1 hour	Allow 1 hour extra if fitting this tray to 4.5L Twin Cam as there is more equipment to relocate.
<b>INCLUDED</b>	
1 X Tray 4 X M8 Bolt Long 1 X M8 Nut 1 X Universal Top Mount 2 X J Bolt	<b>NOTE: If original battery is in middle of engine bay, you require a rear mount auxiliary. If original battery is in rear of engine bay you require a mid mount auxiliary.</b>
<b>LOCATION</b>	<b>NOTE: 4.5L TWIN CAM NOT SUITABLE FOR SELF FIT, DIESEL IS APPROVED FOR SELF FIT.</b>
PSM	

NOT SUITABLE FOR SELF FIT IF 4.5 TWIN CAM  
 APPROVED FOR SELF FIT ONLY IF DIESEL

**LANDCRUISER 75/78/79 SERIES**  
HZJ75 THIRD CRADLE

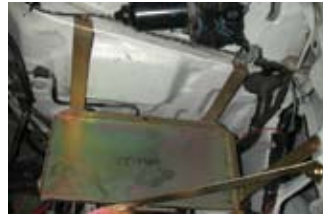

This photo shows the BT75DR tray



This photo shows the BT75DR tray as a triple battery kit

PART NUMBER	FITTING INSTRUCTIONS
BT75DR	The cradle fits passenger side rear in the 75 series cruiser with 1 HZJ 75 model.
<b>BATTERY SIZE</b>	
12 inch - ED5	It can only be used in conjunction with our 75 dual tray as it bolts to this tray.
<b>APPROX. FITTING TIME</b>	
½ hour	The tray sits east-west behind the dual tray below the wiper motor. The two rear uprights sit down on the lip of the fire wall. The single arm lines up with a captive nut on the skirt.
<b>INCLUDED</b>	
1 X Tray 3 X M6 Bolt 3 X M6 Nut 1 X Body Washer 1 X M8 Bolt Long 1 X M8 Nut 1 X Universal Top Mount 2 X J Bolts	
<b>LOCATION</b>	
PSR	

NOT SUITABLE FOR SELF FIT

**LANDCRUISER 75/78 & 79 SERIES**  
HZJ75 (TROOP or UTE) DUAL CRADLE



BT75D AND BT78D



TRIPLE BATTERY KIT

PART NUMBER	FITTING INSTRUCTIONS
BT75D/BT78D	The cradle fitted passenger side middle and is mounted on the skirt and rail.
<b>BATTERY SIZE</b>	
12 inch X 2 - ED5	This cradle is designed for the 4.2L diesel 75 series, and takes two 12 inch case batteries.
<b>APPROX. FITTING TIME</b>	
2 hours	It fits up to original bolt holes. Sometimes, you may have to move the standard loom and relays and relocate them away from the tray's mounting points. The fitting of this tray also allows for a third battery to be fitted at the rear, facing east-west across the fire wall. The third
<b>INCLUDED</b>	
1 X Tray 1 X M8 Nut 1 X Weld Bolt 4 X M8 Bolt long 1 X M8 Nut 2 X Universal top mount 4 X J Bolt	
<b>LOCATION</b>	
PSMT	

NOT SUITABLE FOR SELF FIT

**LANDCRUISER 78/79 SERIES**  
ALL DIESEL MODELS



PART NUMBER	FITTING INSTRUCTIONS
BT78R / 79R	The cradle fits passenger side rear.
<b>BATTERY SIZE</b>	
12 inch- ED5	The looms may have to be moved slightly, to ensure that they are not squashed. The computer has to be moved, this gets reattached to the side of the tray.
<b>APPROX. FITTING TIME</b>	
1 hour	Bolt in top arms M8 bolts. Then drill 6mm holes, where required and fasten with M6 bolts and nuts, using body washers under the guard.
<b>INCLUDED</b>	
1 X Tray 1 X M6 Bolt 3 X M6 Nut 3 X Body Washer 2 X M8 Body Short 1 X Universal Top Mount 2 X J Bolts	No problems to fit.
<b>LOCATION</b>	
PSR	

APPROVED FOR SELF FIT

**LANDCRUISER 80**  
1HZD/1HDT/1HDFT TD



<b>PART NUMBER</b>
BT80D
<b>BATTERY SIZE</b>
12 inch- ED5
<b>APPROX. FITTING TIME</b>
1 hour
<b>INCLUDED</b>
1 X Tray
1 X M6 Bolt (see note)
1 X M6 Nut
1 X Body Washer
3 X M6 Bolt Long
1 X M6 Bolt Short
1 X Special top mount
2 X J Bolts
<b>LOCATION</b>
DSF

**FITTING INSTRUCTIONS**

The cradle fits drivers side front.

Sits up on existing bolts, only one hole to be drilled.

**NOTE: Top mount must be used to ensure no rocking movement in battery. This tray can be used to replace original manufacturers cradle on some petrol vehicles.**



**LANDCRUISER 80 SERIES**  
3.9 EFI AUTO

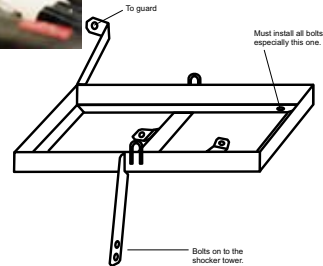

<b>PART NUMBER</b>
BT80PE
<b>BATTERY SIZE</b>
12 inch- ED5
<b>APPROX. FITTING TIME</b>
1 hour
<b>INCLUDED</b>
1 X Tray
6 X M6 Bolt
6 X M6 Nut
3 X Body Washer
1 X Universal top mount
2 X J Bolts
<b>LOCATION</b>
PSR

**FITTING INSTRUCTIONS**

The cradle fits passengers rear.

No major problem to install but must have all bolts mounted, if not it will rock and cause damage.



**LANDCRUISER 80 SERIES**  
3F PETROL (Carby)

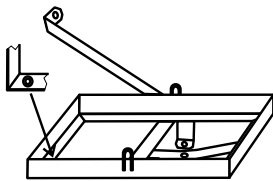

<b>PART NUMBER</b>
BT80PO
<b>BATTERY SIZE</b>
12 inch- ED5
<b>APPROX. FITTING TIME</b>
1 hour
<b>INCLUDED</b>
1 X Tray
6 X M6 Bolt (see note)
6 X M6 Nut
3 X M6 Bolt Long
1 X Universal top mount
2 X J Bolts
<b>LOCATION</b>
DSF

**FITTING INSTRUCTIONS**

The cradle fits drivers side front.

To fit this cradle the washer bottle will need to be relocated. Only one hole has to be drilled, this is the counter sunk hole in the corner. The other holes are already in the vehicle.



**LANDCRUISER 80 SERIES**  
4.5 L Petrol EFI (Twin cam)



<b>PART NUMBER</b>
BT80TC
<b>BATTERY SIZE</b>
12 inch -ED5
<b>APPROX. FITTING TIME</b>
1 hour (2 hours if cruise fitted)
<b>INCLUDED</b>
1 X Tray
1 X Washer Bracket
4 X M6 Bolt
1 X M6 Bolt (see note)
5 X M6 Nut
1 X Body Washer
1 X M6 Bolt
1 X M6 Nut
4 X M6 Bolt Short
2 X M6 Bolt Long
1 X Special top mount
1 X Air Cleaner Bracket
2 X J Bolts
<b>LOCATION</b>
DSF

**FITTING INSTRUCTIONS**

The cradle fits drivers side front.

Make sure looms are not squashed when fitting the cradle. For Twin Cam engines, the washer bottle mount and air cleaner brackets have to be used. The washer bottle is relocated to the rear right guard, using the washer mount bracket. One M6 hole has to be drilled, and hoses and wires extended. The other bracket is used to move the air pressure sensor further to the right on the air cleaner.

**NOTE: IF FACTORY CRUISE FITTED - NOT FOR SELF FIT. The top mount must be used to ensure no rocking movement in battery..**



**LANDCRUISER 100 SERIES**  
1HZ 6cyl 4.2 Diesel 1FZFE 6cyl 4.5 Petrol

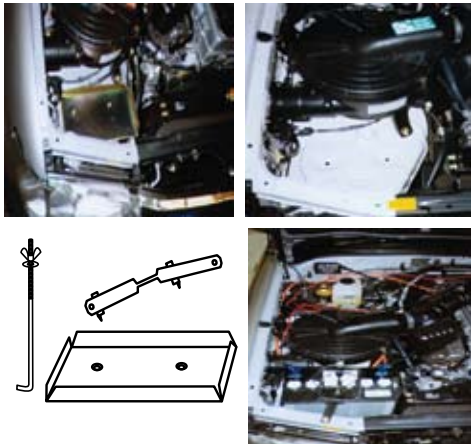

PART NUMBER
BT100
BATTERY SIZE
12 inch - ED5
APPROX. FITTING TIME
30 min
INCLUDED
1 X Tray
2 X M8 Bolt (incl. wash)
2 X M6 Nut
2 X Body Washer
1 X M8 Bolt Short
1 X J Bolt
1 X Special top mount
LOCATION
DSF

**FITTING INSTRUCTIONS**

The cradle fits all 100 series petrol/diesel with 6 cylinder engine, not V8, and mounts to drivers side front.

Two holes already exist, no drilling required. Top mount must be used only one J bolt required.

This is a very simple fit up.

**NOTE:** It is possible to put the BT100R 3rd tray in any 100 series if required.



**LANDCRUISER 100 SERIES**  
1HDFTE 6 Cyl 4.2 TDI (Third Tray)

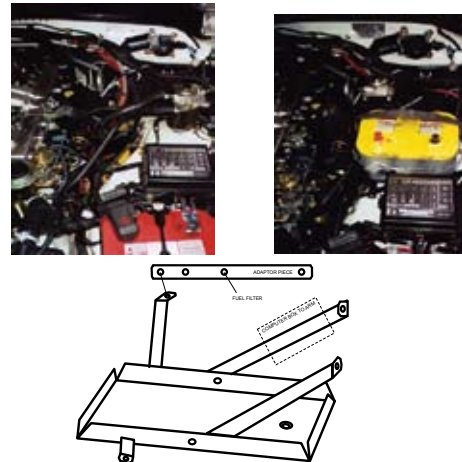

PART NUMBER
BT100R
BATTERY SIZE
10 inch - ED50
APPROX. FITTING TIME
2 Hours
INCLUDED
1 X Tray
4 X M8 Bolt
1 X M8 Bolt (incl. sunk)
1 X M6 Nut
3 X Body Washer
1 X M8 Nut
2 X M8 Bolt Long
2 X M8 Bolt Short
2 X M6 Nut
1 X Universal Top mount
2 X J Bolts
LOCATION
PSR

**FITTING INSTRUCTIONS**

This tray fits diesel with factory twin battery, also V8 and 4.5 twin cam petrol.

Locates third or aux. battery in passenger side toward back corner of guard in diesel. Re-located fuel filter to adaptor this bridges fire wall to side of tray. No modifications to fuel hose.

**NOTE:** Computer on diesel MUST earth correctly. Return filter mounts to engine side tray (no hole). It is possible to put the BT100R 3rd tray in any 100 series if required.



**LANDCRUISER 100 SERIES**  
4.7L V8 PETROL



PART NUMBER
BT100V8
BATTERY SIZE
12 Inch - ED5
APPROX. FITTING TIME
1.5 hours
INCLUDED
1 x Tray
1 x PwrSteer hose.
4 x M6 Cir Sunk bolts
3 x body washer
1 x M6 Nut
1 x special top mount
1 x M6 Bolt
4 x M6 Nuts
1 x M6 Cir Sunk bolts
2 x Reinforcing Plate
2 x J Bolts
LOCATION
DSF

**FITTING INSTRUCTIONS**

This tray fits drivers side front.

- Remove power steering bracket from reservoir.
- Drill out spot welds on power steering bracket. Separate the side that holds the reservoir. (see Fig. 1 & 2)
- Drain power steering reservoir.
- Replace power steering flexible line, with hose supplied, from bottle to front metal liner.
- Shorten power steering line from pump to bottle, at the bottle end to avoid hose kink, then replace.
- Mount power steering bracket on battery tray, counter sink top right hand bolt – as you look at it.
- Place battery tray in vehicle, ensure reinforcing plates are fitted under body to hold tray down – THESE PLATES MUST BE USED. Mount power steering bottle onto mounting position on tray.
- Bolt tray into position – refill power steering bottle. (see Fig. 3 & 4)



**LANDCRUISER 200 SERIES**  
4.7 L V8 TD



PART NUMBER
BT200V8D
BATTERY SIZE
10 inch - ED50 Optima or Orbital Only
APPROX. FITTING TIME
1.5 hours
INCLUDED
2 x M8 Long
2 x M8 Short
2 x M6 Nut
9 x M6 Hex
1 x M6 CirSunk
1 x M6 Weld Bolt
4 x M6 Nut
1 x Standard Top Mount
4 x Special Brackets
2 x J Bolts
LOCATION
PSR

**FITTING INSTRUCTIONS**

This cradle fit passenger side rear. Remove fuel cannister & mount, terminal box & computers. Longest leg on terminal box has to be cut off. Back corner of computer mount needs to be trimmed to fit around A/C pipe.

- Remove relay from inner guard.
- Place Conduit over fuel line from cannister.
- Bolt computer mounts to inner guard then bolt computer to mounts move into position & tighten all bolts.
- Bolt lower bracket on terminal box & bolt into position.
- Modify relay mounts & bolt into inner guard with terminal mount.
- Bolt terminal box to mount.
- Place tray into position & bolt base mounts with 3 x M6 Hex.
- Bolt mounts to inner guard using 2 x M8 short.
- Bolt cannister to mounts on tray using 2 x M8 long nuts & bolts
- Lengthen wiring to fuel cannister (2x Plugs)

**NOTE:** Standard wet cell battery terminals are too close to bonnet, therefore an Exide Optima / Orbital or Din style standard battery (with recessed terminals) must be used.





**LANDCRUISER 200 SERIES**  
**4.7 L V8 TD**  
**DRIVERS SIDE**  
**REPLACEMENT TRAY**



<b>PART NUMBER</b>
BT200V8DRD
<b>BATTERY SIZE</b>
13 inch Optima or Orbital
<b>APPROX. FITTING TIME</b>
1.0 hour
<b>INCLUDED</b>
3 X M6 HEX 2 X M6 NUTS 2 X M6 WASHERS
<b>LOCATION</b>
DSF

**FITTING INSTRUCTIONS**

This cradle fits drivers side front.

Remove battery and plastic tray.  
Remove inner lining from wheel arch.  
Bolt in replacement tray and re-fit inner guard.



**LANDCRUISER 200 SERIES**  
**4.7 L V8 TD**  
**PASSENGER SIDE**  
**REPLACEMENT TRAY**



<b>PART NUMBER</b>
BT200V8DRP
<b>BATTERY SIZE</b>
13 inch Optima or Orbital
<b>APPROX. FITTING TIME</b>
1.0 hour
<b>INCLUDED</b>
3 X M6 HEX 3 X M6 WASHERS 3 X M6 NUTS
<b>LOCATION</b>
PSF

**FITTING INSTRUCTIONS**

This cradle fits passenger side front

Remove battery and plastic tray.  
Remove inner lining from wheel arch.  
Drill in third bolt hole  
Bolt in replacement tray using the three bolt holes.  
Re-fit inner guard.



**LANDCRUISER 200 SERIES**  
**4.7 L V8 PETROL**



<b>PART NUMBER</b>
BT200PV8
<b>BATTERY SIZE</b>
10 inch - ED50
<b>APPROX. FITTING TIME</b>
1 hour
<b>INCLUDED</b>
1 x Tray 7 x M6 Hex 2 x M6 Nuts 1 x Special Top Mount 2 x J Bolts
<b>LOCATION</b>
DSF

**FITTING INSTRUCTIONS**

This cradle fit drivers side front.

Remove power steering reservoir from inner guard. ( no need to disconnect.)  
Cut reservoir bracket to fit to tray.  
Bolt Tray to inner guard.  
Drill & bolt P.S reservoir bracket to tray & re-install reservoir.  
Remove two clips from plastic guard on radiator support panel.  
Put battery in & top onto battery which braces to radiator support under plastic guard.  
Re-install clips into plastic guard.



**LEXUS LX470**  
**2 UZFE 4.7L PETROL**



<b>PART NUMBER</b>
BTLEXUS
<b>BATTERY SIZE</b>
8 inch - ED4
<b>APPROX. FITTING TIME</b>
1 hour
<b>INCLUDED</b>
3 X M6 BOLT (non-socket) 3 X M6 NUT 3 X BODY WASHER 1 X M6 BOLT (non-socket) 2 X J BOLT 1 x Special Top Mount
<b>LOCATION</b>
DSF

**FITTING INSTRUCTIONS**

The cradle fits drivers side front.

Tray sits flat held down with three counter sunk M6 bolts with nuts and body washers. Before fitting tray remove power steering reservoir, this re-bolts to tray. You may have to shorten one of the power steering hoses to avoid kinking in hose.

**NOTE:** This tray will hold a 10" battery but only use 8" because power steering reservoir re-mounts to tray bed.



## PRADO 90 SERIES 1KZ-TE 3.0 L TDI



PART NUMBER
BTPRAD
BATTERY SIZE
12 inch - ED5
APPROX. FITTING TIME
1/2 hour
INCLUDED
2 X M6 Bolt
1 X M6 Nut
1 X Body Washer
1 X M6 Bolt Short
2 X J Bolt
1 X Tray
1 X Special top mount
LOCATION
PSF

### FITTING INSTRUCTIONS

The cradle fits passenger side front.

Remove air intake pipe that runs along and into the guard.  
Note: You may need to remove inner guard to refit pipe after the tray is in.  
Place tray and make sure arm is under air cleaner support, use existing bolt.  
Screw M6 bolt into existing taped hole in guard. Drill M6 hole under leg at the front of tray. Use M6 nut, bolt and washer.  
Tighten all nuts and bolts. Top bracket must be used.



## PRADO 90 SERIES 5VZ-FE 3.4L V6 PETROL 4 Cyl PETROL (Non ABS)



PART NUMBER
BTPRA4C
BATTERY SIZE
8 inch -ED4
APPROX. FITTING TIME
1 hour
INCLUDED
3 X M6 Bolt
2 X M6 Bolt (one sunk)
1 X M6 Bolt Long
4 X M6 Nut
1 X Body Washer
4 X Small Body Washer
1 X M6 Bolt Short
1 X M6 Bolt
2 X Self Drill Screws
1 X Special top mount
2 X J Bolts
LOCATION
PSR

### FITTING INSTRUCTIONS

The cradle fits passenger side rear.

This cradle fits Prado 4cyl. and Prado V6 non ABS and Hilux 2.7 petrol 99 Model.  
To fit this cradle the charcoal canister must be relocated usually to the driver side next to the brake booster. The hoses for the charcoal canister have to be extended.  
Bolt kit includes bolts and self drill screws to remount charcoal canister on opposite side.



## PRADO 90 SERIES 5VZ-FE 3.4L V6 PETROL 4 Cyl PETROL (Replacement of original tray)



PART NUMBER
BTPRA4CO
BATTERY SIZE
12 inch- ED5
APPROX. FITTING TIME
1/2 hour
INCLUDED
2 X M6 Bolt
1 X M6 Nut
1 X Body Washer
1 X J Bolt
1 X Tray
LOCATION
PSF

### FITTING INSTRUCTIONS

The cradle fits in original position passenger side front.

This cradle uses original bolt holes but allows for a larger size battery.

Remove plastic splash guard, unbolt fuse box. Fit tray then bolt the fuse box in first. You can now drill the M6 down through the lower guard.



## PRADO 120 SERIES 3.0L TDI

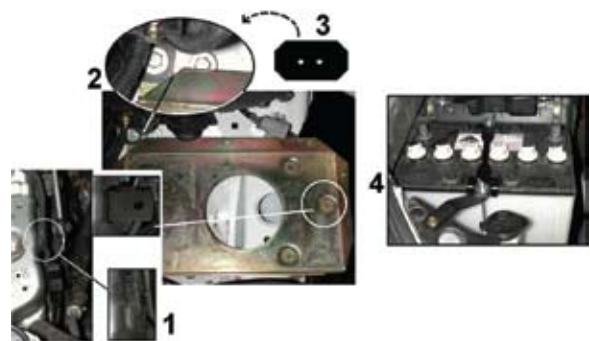

PART NUMBER
BTPRAD03
BATTERY SIZE
12 inch - ED5 Only
APPROX. FITTING TIME
1/2 hour
INCLUDED
1xTray
1xTray support bit
1 x spt plate
6 x M6 Nut
3 x M6 Bolt
1 x Special top mount
5 x M6 cr sunk bolts
1x Washer
1x M6 bolt long
2 x J Bolts
LOCATION
DSF

### FITTING INSTRUCTIONS

The cradle fits drivers side front.

Unclip wiring loom and bolt in supplied right angle bracket using 1xM6 bolt and nut (Pic 1).  
Unbolt junction of earth wires from inner guard, discard bolt.  
Fit the tray in position and using three (3) counter sunk M6 bolts, using long M6 bolt and washer replace earth strap junction together with Battery Tray arm to inner guard.  
Drill 2xM6 holes through the mount on tray and through the wheel arch. Using 2xM6 nuts and bolts, bolt through the tray mount, the wheel arch and the support plate on the under side of the wheel arch (Pic 2+3).  
Place battery in position install supplied top mount, drill through the "4" stamped into the metal of the radiator support, DO NOT follow through drilling or you WILL damage the headlight. Secure top mount with M6 bolt (Pic 4)





**PRADO 120 SERIES**  
4 L V6 PETROL

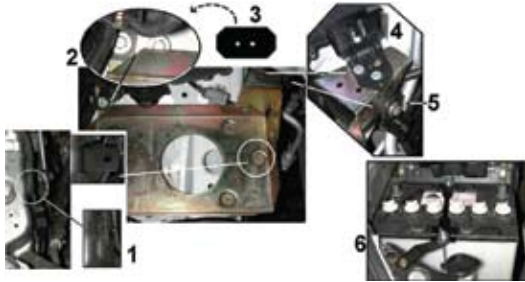

**FITTING INSTRUCTIONS**

<b>PART NUMBER</b>
BTPRAP03
<b>BATTERY SIZE</b>
12 inch - ED5 Only
<b>APPROX. FITTING TIME</b>
1/2 hour
<b>INCLUDED</b>
1 x Tray
1 x support bracket
1 x spt plate
10 x M6 Nut
3 x M6 Bolt
1 x Special top mount
5 x M6 or sunk bolts
1 x Washer
1 x M6 bolt long
2 x J Bolts
5 x Weld bolts
Power steering reservoir bkt
Air intake mount
<b>LOCATION</b>
DSF

- The cradle fit drivers side front.
- Bolt supplied Power Steering Bracket to outer top right hand corner of Battery Tray using 2 x M6 weld bolts.
  - Remove metal bracket on air cleaner duct, retain 2xM6 short bolts. Remount small earth strap out of the way, and remove small bracket holding Air conditioner pipe, separate and retain rubber mounting block to be used later.
  - Unbolt power steering reservoir bracket, drill out the three (3) spot welds on bracket and keep the slide section holding the reservoir this remounts to new bracket at a later stage.
  - Pass the Power Steering reservoir, with hoses connected under and over the Air conditioner pipe, the hoses now run over the air con pipe not under.
  - Unclip wiring loom and bolt in supplied right angle bracket using 1xM6 bolt and nut (Pic 1).
  - Unbolt junction of earth wires from inner guard, discard bolt.
  - Fit the tray in position and using three (3) counter sunk M6 bolts, using long M6 bolt and washer replace earth strap junction together with Battery Tray arm to inner guard.
  - Drill 2xM6 holes through the mount on tray and through the wheel arch. Mount new air cleaner duct bracket, supplied, reusing the short M6bolts. Using 2xM6 nuts and bolts, bolt through the air cleaner duct bracket, the tray mount, the wheel arch and the support plate on the under side of the wheel arch (Pic 2+3).
  - Mount the Air Conditioner pipe to the side of the new Power Steering bracket using rubber mounting block (Pic 5).
  - Sit battery in position, slide Power Steering bracket onto Power Steering reservoir, position reservoir and mark the 3x holes to be drilled out. IMPORTANT: ensure that battery does not rub on reservoir.
  - Remove battery drill out holes to mount Power Steering bracket and secure with 3xM6 weld bolts and nuts (Pic 4)
  - Replace battery install supplied top mount, drill through the "4" stamped into the metal of the radiator support, DO NOT follow through drilling or you WILL damage the headlight. Secure top mount with M6 bolt (Pic 6)



**PRADO 120 SERIES**  
4.5 L V6 PETROL

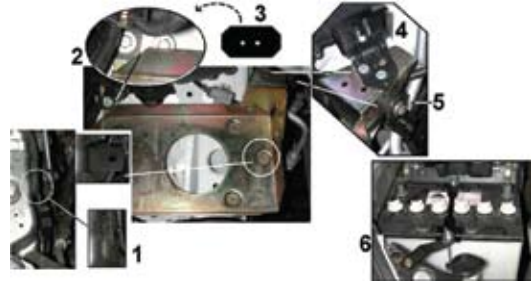

**FITTING INSTRUCTIONS**

<b>PART NUMBER</b>
BTPRAP07
<b>BATTERY SIZE</b>
12 inch - ED5 Only
<b>APPROX. FITTING TIME</b>
1/2 hour
<b>INCLUDED</b>
1 x Tray
1 x tray support bkt
1 x spt plate
6 x M6 Nut
3 x M6 Bolt
1 x Special top mount
5 x M6 or sunk bolts
1 x Washer
1 x M6 bolt long
2 x J Bolts
Power steering reservoir bkt
Air intake mount
<b>LOCATION</b>
DSF

- The cradle fit drivers side front.
- Bolt supplied Power Steering Bracket to outer top right hand corner of Battery Tray using 2 x M6 weld bolts.
  - Remove metal bracket on air cleaner duct, retain 2xM6 short bolts. Remount small earth strap out of the way, and remove small bracket holding Air conditioner pipe, separate and retain rubber mounting block to be used later.
  - Unbolt power steering reservoir bracket, drill out the three (3) spot welds on bracket and keep the slide section holding the reservoir this remounts to new bracket at a later stage.
  - Pass the Power Steering reservoir, with hoses connected under and over the Air conditioner pipe, the hoses now run over the air con pipe not under.
  - Unclip wiring loom and bolt in supplied right angle bracket using 1xM6 bolt and nut (Pic 1).
  - Unbolt junction of earth wires from inner guard, discard bolt.
  - Fit the tray in position and using three (3) counter sunk M6 bolts, using long M6 bolt and washer replace earth strap junction together with Battery Tray arm to inner guard.
  - Drill 2xM6 holes through the mount on tray and through the wheel arch. Mount new air cleaner duct bracket, supplied, reusing the short M6bolts. Using 2xM6 nuts and bolts, bolt through the air cleaner duct bracket, the tray mount, the wheel arch and the support plate on the under side of the wheel arch (Pic 2+3).
  - Mount the Air Conditioner pipe to the side of the new Power Steering bracket using rubber mounting block (Pic 5).
  - Sit battery in position, slide Power Steering bracket onto Power Steering reservoir, position reservoir and mark the 3x holes to be drilled out. IMPORTANT: ensure that battery does not rub on reservoir.
  - Remove battery drill out holes to mount Power Steering bracket and secure with 3xM6 weld bolts and nuts (Pic 4)
  - Replace battery install supplied top mount, drill through the "4" stamped into the metal of the radiator support, DO NOT follow through drilling or you WILL damage the headlight. Secure top mount with M6 bolt (Pic 6)
  - Addition bracket mounts to tray for Air Conditioner line. This is for 2007 model onwards.**



**TOYOTA HILUX**  
2.4 / 2.8 D & 22 R/ 22.8 Petrol

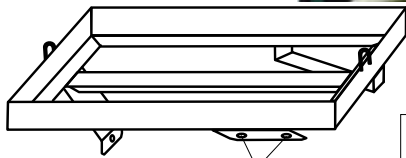
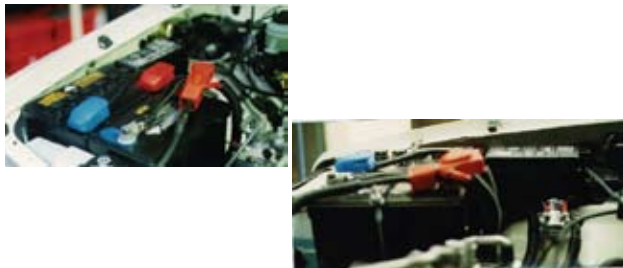

Drill M6 hole  
use M6 nut and bolt.

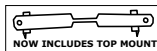

<b>PART NUMBER</b>
BTH2.8
<b>BATTERY SIZE</b>
8 inch + Narrow ED10S
<b>APPROX. FITTING TIME</b>
1 hour
<b>INCLUDED</b>
3 X M6 BOLT
3 X M6 NUT
2 X BODY WASHER
2 X J BOLT
1 X Special Top Mount
<b>LOCATION</b>
DSFT

**FITTING INSTRUCTIONS**

- The cradle fits drivers side front.
- Clearance to guard at back corner is very tight. Also check clearance of battery terminals to bonnet, if not sure do not close bonnet until clearance is correct Battery with off set terminals may be required.
- NOTE: This tray can be used to replace original manufactures cradle.**



**TOYOTA HILUX**  
2.4 D, 2.8 D & 2.8 Petrol  
(Top Mount)

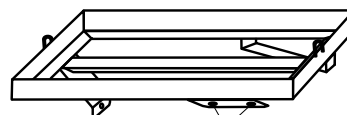
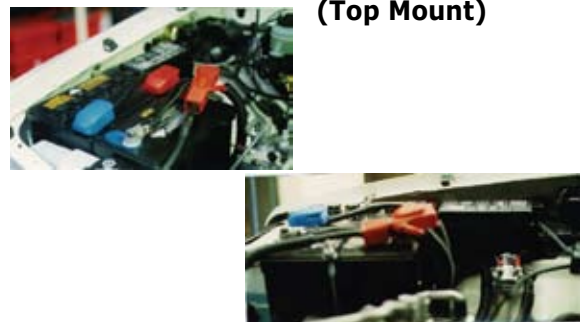

Drill M6 hole  
use M6 nut and bolt.



<b>PART NUMBER</b>
BTH2.4
<b>BATTERY SIZE</b>
8 inch + Narrow ED10S
<b>APPROX. FITTING TIME</b>
1 hour
<b>INCLUDED</b>
2 X M6 Bolt
2 X M6 Nut
1 X Body Washer
2 X M6 Bolt Long
1 X M6 Nut
2 X J Bolt
1 X Special Top Mount
<b>LOCATION</b>
DSFT

**FITTING INSTRUCTIONS**

- The cradle fits drivers side front replacing original.
- This cradle fits two batteries.
- NOTE: Caution is required to check clearance to the bonnet. Off set terminals may be required depending on the choice of battery.**



**TOYOTA 4 RUNNER**  
3V-ZE3L V6 (Top Mount)

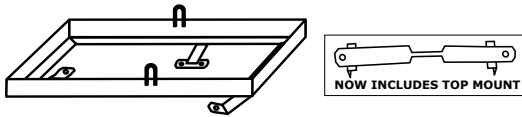

NOW INCLUDES TOP MOUNT

<b>PART NUMBER</b>	BT4R90
<b>BATTERY SIZE</b>	Narrow - ED10S
<b>APPROX. FITTING TIME</b>	1 hour
<b>INCLUDED</b>	4 X M6 Bolt 4 X M6 Nut 4 X Body Washer 1 X Special Top Mount 2 X J Bolts
<b>LOCATION</b>	DSM

**FITTING INSTRUCTIONS**

The cradle fits on the drivers side middle and the original battery.

Fitting this tray is very tight. You will have to move the standard wiring loom around to fit tray. Once you have fitted tray a top clamp can be made that bolts to the guard lip then crosses battery. This will stop any battery movement.



**TOYOTA HILUX**  
3.0 - 5.0 L DIESEL



<b>PART NUMBER</b>	BTH3
<b>BATTERY SIZE</b>	10 inch - ED50
<b>APPROX. FITTING TIME</b>	1/2 hour
<b>INCLUDED</b>	4 X M6 Bolt 1 X M6 Bolt (c/s sunk) 5 X M6 Nut 5 X Body Washer 2 X J Bolt 1 X Special Top Mount
<b>LOCATION</b>	PSF

**FITTING INSTRUCTIONS**

The cradle fits passenger side front.

With this tray, you will need to mark the holes, then remove the tray and pre drill the holes. Use the 6mm bolts and nuts supplied, making sure to use the large body washers under the guard for extra strength.

Very simple to fit.

**NOTE: IF BOOM BOX IS FITTED, IT WILL HAVE TO BE REMOVED TO FIT CRADLE. CHECK WITH CUSTOMER FIRST. ( Noise Factor)**



**TOYOTA HILUX**  
1KZ-TE 3.0L TURBO DIESEL

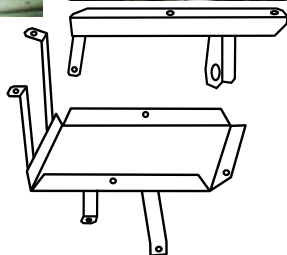
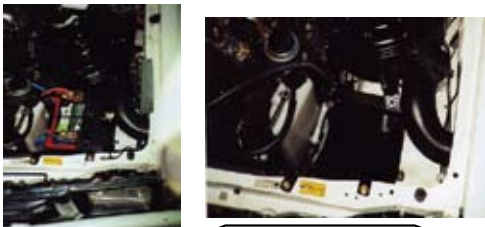

<b>PART NUMBER</b>	BTH3LTD
<b>BATTERY SIZE</b>	8 inch - ED4R
<b>APPROX. FITTING TIME</b>	11/2 hour
<b>INCLUDED</b>	4 X M6 Bolt 1 X M6 Bolt (c/s sunk) 5 X M6 Nut 5 X Body Washer 2 X J Bolt 1 X Universal Top Mount 1 X O'flow Washer bottle bracket
<b>LOCATION</b>	PSF

**FITTING INSTRUCTIONS**

The cradle fits passenger side front.

Remove overflow bottle. Bolt bracket onto radiator mount and bolt bottle onto bracket. Tray sits under air cleaner. Fits straight in but take note of air conditioning lines.



**TOYOTA HILUX**  
3 RZ-FE 2.7 L PETROL



<b>PART NUMBER</b>	BTH2.7
<b>BATTERY SIZE</b>	8 inch - ED4R
<b>APPROX. FITTING TIME</b>	1 hour
<b>INCLUDED</b>	1 x Tray 2 x M6 Hex 1 x M6 C/sunk 1 x M6 bolt long 1 special top mount 2 x M6 Long Bolts 4 x M6 Nut 6 x M6 body washer 1 x Gold Washer 1 x Long Self Tapper (Includes Canister Mounting Kit) 2 X J Bolts
<b>LOCATION</b>	PSR

**FITTING INSTRUCTIONS**

The cradle fits passenger side rear.

Remove charcoal canister from Passenger side. Remount bracket on Driver side using long M6 bolt into captive on top of inner guard. Drill & bolt bottom of bracket. (Modification of guard may be needed.) Self-tapper last mount into top of inner guard. Extend wiring and all hoses to canister. Relocate fuel filter down inner guard approx. 40 mm with self-tapper. Unplug solenoids and re-run wiring down outside of inner guard. Place in tray and bolt two arms with M8 and M6. With M6 bolt/washer and nut, bolt rear bracket into existing hole. Then drill 6mm hole & bolt tray with washer (Gold) between tray and body. Drill second hole in rear bracket and bolt using counter sunk and M6 washer and nut. Run wiring under tray down to solenoids and re-connect. Place Battery in tray. Place top mount over Battery & self-tapper into top of inner guard. To fit this cradle the charcoal canister must be relocated usually to the driver's side next to the brake booster. The fuel filter has to be moved down slightly out of the way. Extend the hose for the canister.



## TOYOTA HILUX 5VZ-FE 3.4 L V6 PETROL

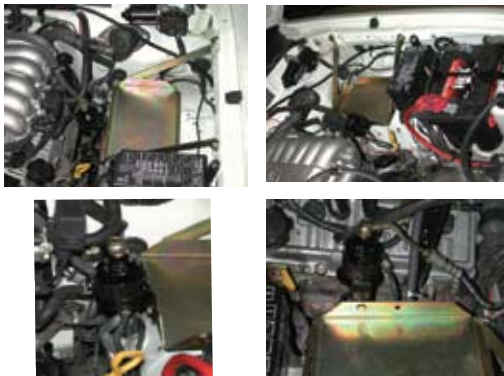

<b>PART NUMBER</b>
BTPRA4C
<b>BATTERY SIZE</b>
8 inch - ED4R
<b>APPROX. FITTING TIME</b>
1 hour
<b>INCLUDED</b>
1 x Tray 2 x M6 Hex 1 x M6 CSunk 1 x M6 bolt long 1 special top mount 2 x M6 Long Bolts 4 x M6 Nut 6 x M6 body washer 1 x Gold Washer 1 x Long Self Tapper (Includes Canister Mounting Kit) 2 x J Bolts
<b>LOCATION</b>
PSR

### FITTING INSTRUCTIONS

The cradle fits passenger side rear.

This cradle fits Prado 4cyl. and Prado V6 non ABS and Hilux 2.7 petrol 99 Model.  
To fit this cradle the charcoal canister must be relocated usually to the driver side next to the brake booster. The fuel filter has to be moved down slightly out of the way. Extend the hose for the canister. Brackets to move the canister are supplied.

**NOTE:** The original starting battery can fit into this auxiliary tray leaving room for 12 inch auxiliary battery to be fitted using a BTPRA4CO.



## TOYOTA HILUX 5VZ-FE 3.4L V6 PETROL 4 Cyl PETROL (Replacement of original tray)



<b>PART NUMBER</b>
BTPRA4CO
<b>BATTERY SIZE</b>
12 inch - ED5
<b>APPROX. FITTING TIME</b>
1/2 hour
<b>INCLUDED</b>
2 X M6 Bolt 1 X M6 Nut 1 X Body Washer 1 X J Bolt 1 X Tray
<b>LOCATION</b>
PSF

### FITTING INSTRUCTIONS

The cradle fits in original position passenger side front.

This cradle uses original bolt holes but allows for a larger size battery.

Remove plastic splash guard, unbolt fuse box. Fit tray then bolt the fuse box in first. You can now drill the M6 down through the lower guard.



## TOYOTA HILUX 1KD-FTV 3.0 L TDI V6 PETROL

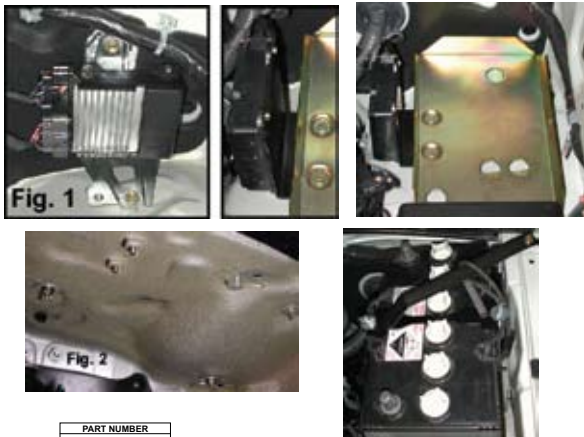

<b>PART NUMBER</b>
BTH05
<b>BATTERY SIZE</b>
12 inch - ED5
<b>APPROX. FITTING TIME</b>
1 hour
<b>INCLUDED</b>
1 x Tray 1 x Comp Bld 2 x 250mm panel washer 2 x J bolt 1 x Special top mount 1 x 50mm M6 Bolt 2 x Black washer 2 x M6 bolt cr sunk 25mm 6 x M6 20mm bolt 4 X M6 Nuts
<b>LOCATION</b>
PSR

### FITTING INSTRUCTIONS

The cradle fits passenger side rear.

Unplug Diesel computer plugs and remove computer and bracket from vehicle.  
Refit diesel computer to new mounting bracket using 3 x OE screws (Fig 1).  
Bolt computer bracket to battery tray using 2 x M6 25mm counter sunk screws and wiz lock nuts (Fig. 1).  
Place battery tray in position, line up with 3 x captive nuts and 2 x OE holes. Secure with nuts, bolts and washers (Fig 2).  
Place battery onto tray and secure top mount to guard using longer bolt and black spacer washers



## NISSAN PATROL MK-MQ SD33F3 3.0 D/SD33T 3.3TD

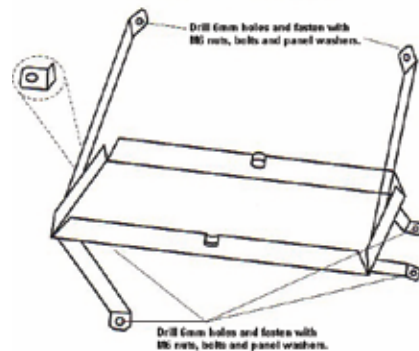

<b>PART NUMBER</b>
BTM0D
<b>BATTERY SIZE</b>
12 inch - ED5
<b>APPROX. FITTING TIME</b>
1 hour
<b>INCLUDED</b>
6 X M6 Bolt 6 X M6 Nut 6 X Body Washer 2 X J Bolt 1 X Universal Top Mount
<b>LOCATION</b>
DSM

### FITTING INSTRUCTIONS

The cradle fits opposite the existing battery drivers side middle.

These instructions are the same for right hand or left hand side mounting. The tray sits opposite the existing battery and is held in with 6 x M6 nuts and bolts with panel washers. (note before drilling any holes check battery height in relation to the bonnet as you may have to lower the tray down slightly). You must use panel washers on the vehicle as the skirt and rail are very weak and will crack if you don't use the extra washers supplied. Once you have checked the height, mark and drill holes. You may have to remove the guard lined to put the top washer and nuts on. Place the battery in the tray and cover the terminals up, then check the bonnet clearance.





## NISSAN PATROL MK-MQ 2.8 L 6 Cyl Petrol



PART NUMBER
BTMQP
BATTERY SIZE
12 inch - ED5
APPROX. FITTING TIME
1 hour
INCLUDED
6 X M6 Bolt
6 X M6 Nut
6 X Body Washer
2 X J Bolt
1 X Universal Top Mount
LOCATION
BTMQP - PSM

### FITTING INSTRUCTIONS

The cradle fits opposite the existing battery passenger side middle. These instructions are the same for right hand or left hand side mounting. The tray sits opposite the existing battery and is held in with 6 x M6 nuts and bolts with panel washers, (note before drilling any holes check battery height in relation to the bonnet as you may have to lower the tray down slightly). You must use panel washers on the vehicle as the skirt and rail are very weak and will crack if you don't use the extra washers supplied. Once you have checked the height, mark and drill holes. You may have to remove the guard lined to put the top washer and nuts on. Place the battery in the tray and cover the terminals up, then check the bonnet clearance.



## NISSAN PATROL GQ TD 42 4.2 L DIESEL

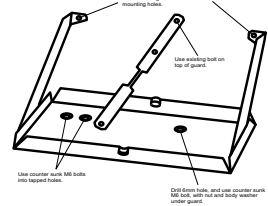

PART NUMBER
BTGQD
BATTERY SIZE
12 inch - ED5
APPROX. FITTING TIME
1 hour
INCLUDED
1 X M6 Bolt
3 X M6 Bolt (one sunk)
2 X M6 Nut
1 X Body Washer
2 X J Bolt
1 X Special Top Mount
LOCATION
PSM

### FITTING INSTRUCTIONS

The cradle fits passenger side middle.

The original bolts for the washer bottle are removed, and the cradle picks up off these points. Replace the M6 bolts, with the cradle against the guard, and the washer bottle in front. Two of the counter sunk mountings will bolt straight in the guard, with M6 counter sunk bolts. The last hole will need to be drilled with a 6mm drill and fastened with a counter sunk bolt, with a nut and body washer under the guard.



## NISSAN PATROL GQ RD 28T 2.8 TD (With Snorkel)

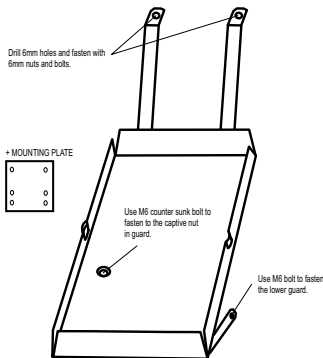

PART NUMBER
BTGQ2.8
BATTERY SIZE
12 inch - ED5
APPROX. FITTING TIME
1 hour
INCLUDED
3 X M6 Bolt
1 X M6 Bolt (one sunk)
3 X M6 Nut
1 X Body Washer
2 X Long Self Tap
2 X J Bolt
1 X Universal Top Mount
1 X Mounting plate
LOCATION
PSR

### FITTING INSTRUCTIONS

The cradle fits passenger side rear.

The cradle faces north and south in the vehicle with the two arms of the cradle sitting on the lip of the fire wall. These are bolted with M6 nut and bolts supplied. The short arm needs a M6 nut and bolt. The hole in the base lines up with a captive hole and a counter sunk M6 bolt is used here. The large oval charcoal canister bracket is removed. A mounting plate for this is supplied. The canister is mounted on the skirt with two self drilling screws supplied. The hoses have to be extended approx. 600mm. 3/8 inch hose is required to do this. Before removing the hoses, make sure you mark them so you don't forget where they originally went.



## NISSAN PATROL GQ TB42 E 4.2L PETROL

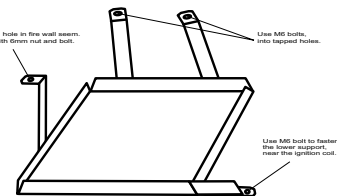

PART NUMBER
BTGQP
BATTERY SIZE
8 inch - ED4
APPROX. FITTING TIME
1 hour
INCLUDED
4 X M6 Bolt
1 X M6 Nut
2 X J Bolt
1 X Universal Top Mount
LOCATION
PSR

### FITTING INSTRUCTIONS

The cradle fits passenger side rear.

First bolt the two support arms into the left guard using M6 bolts into two original tapped holes. Bolt the bottom arm into tapped hole near the ignition coil. Note the coil may need to be moved slightly. The other support arm that rests against the fire wall needs a 6mm hole drilled, then fastened with M6 nut and bolt.



## NISSAN PATROL GU TB45E 4.5 EFI PETROL (Non ABS)

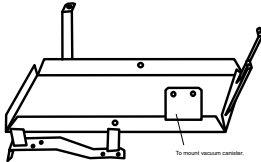

<b>PART NUMBER</b>
BTGUP
<b>BATTERY SIZE</b>
12 inch - ED5
<b>APPROX. FITTING TIME</b>
1 1/2 hours
<b>INCLUDED</b>
4 X M6 BOLT
1 X M6 NUT
1 X BODY WASHER
2 X M8 BOLT LONG
1 X M8 NUT
2 X J BOLT
1 X Universal top mount
<b>LOCATION</b>
PSR

### FITTING INSTRUCTIONS

The cradle fits passenger side rear.

Several pipes need relocation. It is vital this work is done by a qualified person. The three breather pipes going into this side of the guard require modification to clear the tray. The vacuum canister mounts on to the plate on the tray. It is important to retain the one way valve in the rubber hose.

**NOTE: Can not be fitted to vehicle with ABS.**



## NISSAN PATROL GU RD28 TEI 2.8 L TD (Non ABS)



<b>PART NUMBER</b>
BTGU2.8D
<b>BATTERY SIZE</b>
12 inch - ED5
<b>APPROX. FITTING TIME</b>
1 hour
<b>INCLUDED</b>
4 X M6 Bolt
3 X M8 Nut
2 X Body Washer
2 X J Bolt
1 X Universal Top Mount
<b>LOCATION</b>
PSR

### FITTING INSTRUCTIONS

The cradle fits passenger side rear.

Several pipes need relocation. It is vital this work is done by a qualified person. The three breather pipes going into this side of the guard require modification to clear the tray. Re-mount solenoid valves onto the side of the tray. Check clearance between solenoid valves and vacuum hose.

**NOTE: Can not be fitted to vehicle with ABS.**



## NISSAN GU PATROL TB48E 4.8L PETROL (Non ABS)

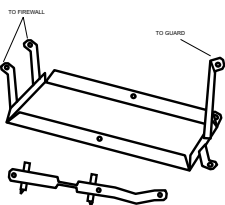

<b>PART NUMBER</b>
BTGU4.8P
<b>BATTERY SIZE</b>
12 inch - ED5
<b>APPROX. FITTING TIME</b>
1 hour
<b>INCLUDED</b>
3 X M6 Bolt
3 X M6 Nut
2 X Body Washer
1 X M8 Bolt Short
1 X M8 Bolt Long
1 X M8 Nut
2 X J Bolt
1 X Special Top Mount
<b>LOCATION</b>
PSR

### FITTING INSTRUCTIONS

The cradle fits passenger side rear.

It locates to side of guard and firewall on the back passenger corner. 12in battery. Charcoal cannister and cruise control relocate.

**NOTE: Can not be fitted to vehicle with ABS.**



## NISSAN PATROL GU TD42 4.2L D & TD42-TD (Non ABS)



<b>PART NUMBER</b>
BTGU4.2TD
<b>BATTERY SIZE</b>
12 inch - ED5
<b>APPROX. FITTING TIME</b>
1 hour
<b>INCLUDED</b>
7 x M6 Chuck
5 x M6 Nut
4 x M6 Hex
1 x M6 Body washer
1 x Special Top Mount
2 x J Bolts
Reinforcing plate
<b>LOCATION</b>
PSM

### CRADLE FITTING INSTRUCTIONS

The cradle fits passenger side middle.

The top mount supplied must be used. Remove the overflow bottle bolts and fit onto counter sunk bolts used as studs to back of cradle. Cradle can now be fitted, then bottle. Bottom hole on bottle needs to be drilled





**NISSAN PATROL GU**  
2D30-TEI 3.0 L / TD42-4.2L TDI



<b>PART NUMBER</b>
BTGU4.2TDI
<b>BATTERY SIZE</b>
12 inch - ED5
<b>APPROX. FITTING TIME</b>
1 hour
<b>INCLUDED</b>
1 x Tray
1 x Spec tray mount bit
5 x M6 bolt
4 x M6 nut
1 x Panel washer
2 x Spacers
1 x Special top mount
1 x O/flow bit
6 x Ch-nut/bolts
1 x 40mm long M6 Bolt inc washer
2 x J Bolt
<b>LOCATION</b>
PSM

**FITTING INSTRUCTIONS**

The cradle fits passenger side middle.

- Remove radiator overflow bottle support bracket.
- Remove bolt from bracket holding overflow bottle hose from inner guard.
- Fit tray-mounting bracket to inner guard, (fig. 1).
- Mount battery tray in position, re attach overflow hose to bracket on tray, (Fig. 2).
- Fit new overflow bottle stabiliser bracket to overflow bottle and tray, (Fig. 3)
- Install top mount using spaces to space bolt on passenger side guard, top mount must be used (Fig. 4)



**NISSAN PATROL GU**  
4.5 L SAFETY PACK

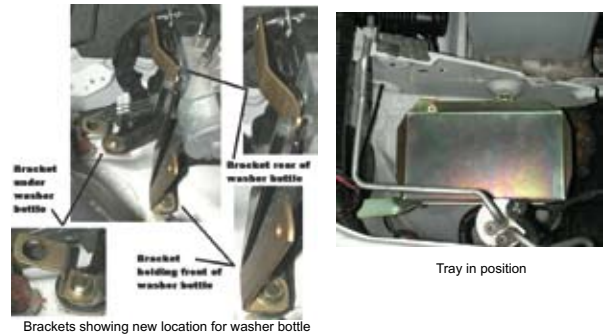

**NISSAN PATROL GU**  
4.5 L SAFETY PACK  
continued.....

**FITTING INSTRUCTIONS**

Suitable for 4.5 and 4.8 petrol with ABS. Tray fits behind headlight in washer bottle location. Washer bottle relocates to beside ABS unit, hoses and wiring needs to be lengthened.

- Remove washer bottle from vehicle (Original position shown in 1st picture).
- Disconnect main battery and remove plastic cowl.
- Place battery tray into position (3rd Pic) - using original earth bolt on inner guard, bolt leg into position.
- Place weld bolt in position on the side of the tray and tighten with nut.
- Drill hole in top of guard and place bolt.
- Line up bottom leg with plastic trim clip hold and drill hole through leg - Replace trim clip with nut and bolt.
- Bolt washer bottle brackets onto ABS unit (2nd Pic). Place washer bottle into position (1st Pic), extend washer motor wiring and re-route washer bottle lines onto washer motor.

<b>PART NUMBER</b>
BTGUSP
<b>BATTERY SIZE</b>
Narrow - ED10S
<b>APPROX. FITTING TIME</b>
4 Hours
<b>INCLUDED</b>
1 x Tray
5 x M6 Bolt
5 x Panel Washer
2 x M6 Bolt Long
1 x Special top mount
5 x M6 Nut
3 x Brackets
2 x J Bolts
3 x Self-tapping Screws
2 x M6 nuts
1 x M6 weld bolt
<b>LOCATION</b>
DSF



**NISSAN PATHFINDER**  
4 CYL PETROL

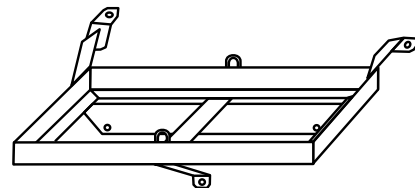

<b>PART NUMBER</b>
BTNP
<b>BATTERY SIZE</b>
8 inch - ED4
<b>APPROX. FITTING TIME</b>
2 hours
<b>INCLUDED</b>
5 X M6 BOLT
5 X M6 NUT
5 X BODY WASHER
2 X J BOLT
1 X Universal top Mount
<b>LOCATION</b>
PSR

**FITTING INSTRUCTIONS**

The cradle fits passenger rear.

The charcoal canister will have to be relocated. Drill and bolt to guard. Make sure to use body washers to stop the inner guard cracking when mounting.

NOTE: it is possible to swap main and auxiliary positions and install 12 inch battery in original position as an auxiliary and 8 inch as the main battery.



## NISSAN PATHFINDER V6 PETROL

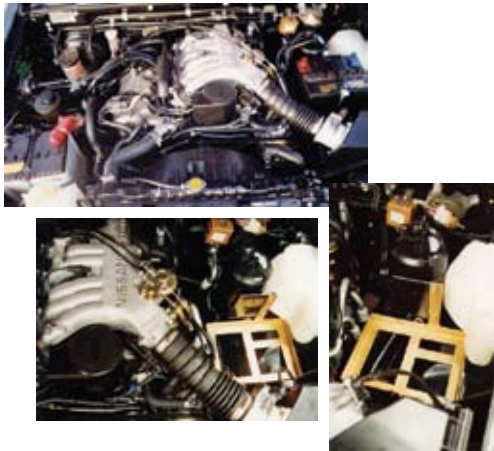

<b>PART NUMBER</b>	BTNPV6
<b>BATTERY SIZE</b>	8 inch - ED4
<b>APPROX. FITTING TIME</b>	2 hours
<b>INCLUDED</b>	6 X M6 Bolt 2 X M6 Nut 2 X J Bolt 1 X Universal Top Mount
<b>LOCATION</b>	PSM

### FITTING INSTRUCTIONS

The cradle fits passenger side rear.

Requires relocation of washer bottle, various hoses and charcoal canister. Charcoal canister mounts onto the angle bracket facing towards the firewall. Check the battery height to bonnet once the tray is in place.

**NOTE: Very fiddly to fit. Old body shape V6 pathfinder only.**

**NOTE: it is possible to swap main and auxiliary positions and install 12 inch battery in original position as an auxiliary and 8 inch as the main battery.**



## NISSAN PATHFINDER 4 Cyl DIESEL & PETROL (Twin 1996 Onwards)

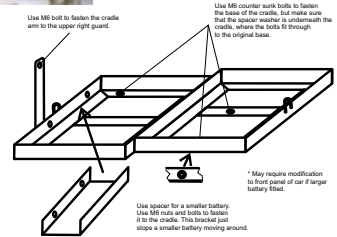
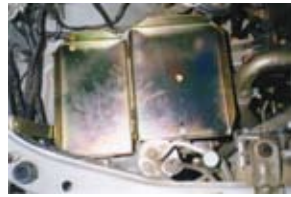

<b>PART NUMBER</b>	BTPF
<b>BATTERY SIZE</b>	8 inch + Narrow ED4
<b>APPROX. FITTING TIME</b>	1 hour
<b>INCLUDED</b>	3 X M6 Bolt 3 X M6 Bolt (c/s sunk) 2 X M6 Nut 2 X J Bolt 1 X Special Top Mount
<b>LOCATION</b>	DSFT

### FITTING INSTRUCTIONS

The cradle replaces the existing tray drivers side front.

To install the Pathfinder dual battery tray, the original tray and associated brackets have to be removed first. The vertical support arm mounts on the right hand guard, into an original 6mm tapped hole. The three counter sunk holes pick up off existing tapped holes. Use 6mm counter sunk bolts with a spacer washer underneath each hole. When trying to fit two 8" case batteries, the battery nearest the guard will fowl on the top lock panel. You will have to bend or cut the corner of the lock panel to fit the battery case.

**NOTE: A top bracket is not supplied as a complete unit due to the possible differences in heights between different battery combinations.**



## NISSAN PATHFINDER V6 PETROL 2006 Onwards (Twin)

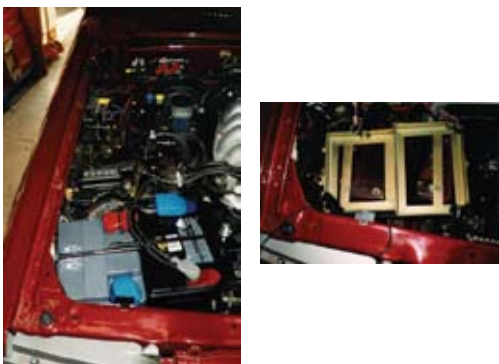

<b>PART NUMBER</b>	BTPF8
<b>BATTERY SIZE</b>	8 inch + 8 inch ED4
<b>APPROX. FITTING TIME</b>	1 1/2 hour
<b>INCLUDED</b>	1 X Tray 3 X M6 bolts 3 X M6 bolt c/s sunk 1 X special top mount 2 X M6 nut 2 X J Bolt
<b>LOCATION</b>	DSF

### FITTING INSTRUCTIONS

This cradle replaces the existing tray and fits in Drivers side front.

To install the Pathfinder dual battery tray, the original tray and associated brackets have to be removed first. The vertical support arm mounts on the right hand guard, into an original 6 mm tapped hole. The three counter sunk holes pick up off existing tapped holes. Use 6mm counter sunk bolts with spacer washer underneath each hole.

**NOTE: When trying to fit the two 8" case batteries, the battery nearest guard will fowl on the top lock panel. You will have to bend the corner of the lock panel to fit the battery case.**



## NISSAN PATHFINDER 2.5Lt Turbo Diesel Inter cooled



<b>PART NUMBER</b>	BTPF06
<b>BATTERY SIZE</b>	10 inch - ED50
<b>APPROX. FITTING TIME</b>	1 hour
<b>INCLUDED</b>	1 X Tray 1 X Back-up plate 2 X M6 bolt 5 X M6 bolt long 6 x M6 nut 1 X Special Top mount 2 X M6 Nut 1 X M6 bolt Short
<b>LOCATION</b>	DSF Under Vehicle

### FITTING INSTRUCTIONS

This tray fits beneath the vehicle on chassis, driver's side.

Safety First – Place vehicle on hoist, if no hoist available, jack vehicle to a comfortable height and secure with stands. Wire one end of positive and negative battery cables into Anderson plug and attach other end of cables to respective terminals. **NOTE: After tray is fitted terminals are extremely hard to reach.** Fit Optima battery to cradle, negative terminal furthest inside tray. As seen in first image. Lift the whole tray including battery, cables and Anderson plug all fitted into position, onto the chassis rail as far as possible forward to maximise. Exhaust – Battery clearance. Secure tray into position using backing plate. Shown in second image. Wire up Isolator and fuse box on firewall as shown in last image.



**NISSAN NAVARA**  
2.7 PETROL (With Pre cleaner)

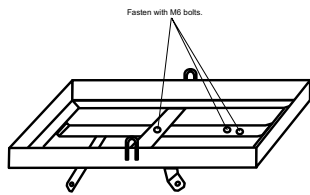

PART NUMBER
BTNNP
BATTERY SIZE
8 inch - ED4R
APPROX. FITTING TIME
1 hour
INCLUDED
4 X M6 Bolt
2 X J Bolt
1 X Universal Top Mount
LOCATION
PSF

**FITTING INSTRUCTIONS**

The cradle fits passenger side front.

The ducting and pre cleaner are removed.

**NOTE:** Ducting reduces induction noise. This fitment may not be suitable for some applications. Check with customer as induction noise is very loud.



**NISSAN NAVARA**  
2.8 DIESEL (Non Pre-cleaner)

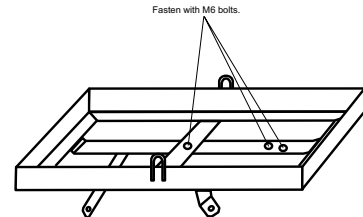

PART NUMBER
BTNND
BATTERY SIZE
12 inch - ED5
APPROX. FITTING TIME
1 hour
INCLUDED
4 X M6 Bolt
2 X J Bolt
1 X Universal Top Mount
LOCATION
PSF

**FITTING INSTRUCTIONS**

The cradle fits front passenger side.

**Note:** Ducting reduces induction noise. This fitment may not be suitable for some applications. Check with customer as induction noise is very loud.



**NISSAN NAVARA**  
D22 V6 PETROL & 3.0 L TD

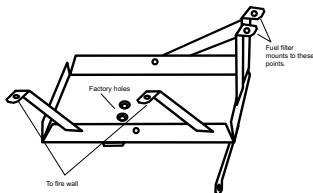

PART NUMBER
BTNDR
BATTERY SIZE
8 inch - ED4
APPROX. FITTING TIME
1 hour
INCLUDED
5 X M6 Bolt
2 X M6 Nut
2 X M8 Bolt Long
2 X M8 Nut
2 X J Bolt
1 X Universal Top Mount
LOCATION
PSR

**FITTING INSTRUCTIONS**

The cradle fits passenger side rear.

It fits to rear passenger side corner. Two factory holes locate position. Slight modification to metal fuel line so as rubber fuel line does not kink. Fuel hose to be shortened.

ED4R Battery with low terminals is required for adequate clearance



**NISSAN NAVARA**  
D40 2.5 L



PART NUMBER
BTPF06
BATTERY SIZE
10 inch - ED50
APPROX. FITTING TIME
1 hour
INCLUDED
1 x Tray
1 x Backup plate
2 x M6 Bolt
5 x M8 Bolt Long & 5 x M8 Nut
1 x Special Top mount
2 x M6 Nut
1 x M6 Bolt Short
LOCATION
DSF Under Vehicle

**FITTING INSTRUCTIONS**

This tray fits beneath the vehicle on chassis, driver's side.

Safety First – Place vehicle on hoist, if no hoist available, jack vehicle to a comfortable height and secure with stands. Wire one end of positive and negative battery cables into Anderson plug and attach other end of cables to respective terminals. **NOTE: After tray is fitted terminals are extremely hard to reach.** Fit Optima battery to cradle, negative terminal furthest inside tray. As seen in first image. Lift the whole tray including battery, cables and Anderson plug all fitted into position, onto the chassis rail as far as possible forward to maximise. Exhaust – Battery clearance. Secure tray into position using backing plate. Shown in second image. Wire up Isolator and fuse box on firewall as shown in last image.





**NISSAN TERRANO 2**  
4 Cyl TURBO DIESEL

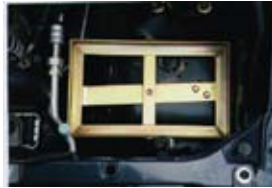

PART NUMBER
BTNTD
BATTERY SIZE
12 inch - ED5
APPROX. FITTING TIME
1 hour
INCLUDED
4 X M6 Bolt 2 X J Bolt 1 X Universal Top Mount
LOCATION
PSF

**FITTING INSTRUCTIONS**

The cradle fits passenger side front.

The holes in the cradle will line up with captive nuts in the body. Four M6 bolts are supplied, and a battery hold down.



**NISSAN XTRAIL**  
4 Cyl EFI PETROL

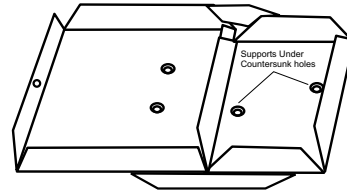

PART NUMBER
BTXTR
BATTERY SIZE
8 inch + Narrow ED4
APPROX. FITTING TIME
1 hour
INCLUDED
1 X Tray 4 X M6 Nuts 4 X M6 Panel Washers 1 X Universal top mount 4 X M6 bolts Cr Sunk 2 X J Bolt
LOCATION
PSFT

**FITTING INSTRUCTIONS**

The cradle fits passenger side front in the original cradle.

It takes a narrow and standard 8in battery. Fitting is basically removing fuse box and making up a new bracket from the original bracket by drilling out spot welds and removing 'L' shaped angle base then bolting to new battery tray via spot weld holes.



**MITSUBISHI PAJERO NA- NG**  
4D56 2.5 D / 4D56T 2.5TD

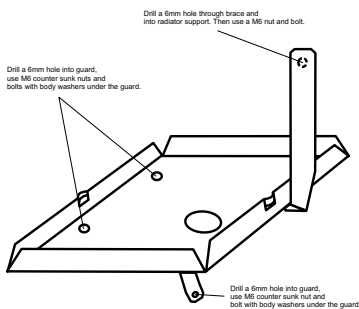

PART NUMBER
BTMPO
BATTERY SIZE
8 inch - ED4
APPROX. FITTING TIME
1 hour
INCLUDED
2 X M6 Bolt 2 X M6 Bolt (non suit) 4 X M6 Nut 3 X Body Washer 2 X J Bolt 1 X Universal Top Mount
LOCATION
PSF

**FITTING INSTRUCTIONS**

The cradle fits passenger side front.

Air conditioning pipes may have to be slightly modified for fitment of cradle. A vacuum sensor may also have to be moved. The top brace of the cradle rests flush with the radiator support bracket and is bolted. The two counter sunk holes are drilled into the guard, using a 6mm drill. Fasten with counter sunk bolts and use body washers and 6mm nuts. Now drill the lower support with a 6mm drill. Use a M6 nut and bolt with a body washer, under the guard. The top brace, which uses the radiator support, has to be positioned so that the cradle is level. A clamp may be of some assistance when you do this. Then drill a 6mm hole through brace and radiator support. Use a M6 nut and bolt to fasten brace.



**MITSUBISHI PAJERO NH-NL**  
6G72 3.0 L Petrol/4D56-4.5 LD/4D56T-4.5TD

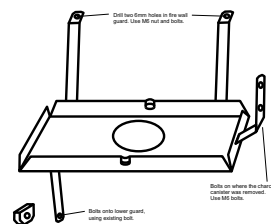

Note: A 10" cradle is also available for Pajero with dual air conditioning (part no. BTMPN10)

PART NUMBER
BTMPN
BATTERY SIZE
12 inch - ED5
APPROX. FITTING TIME
1 hour
INCLUDED
4 X M6 Bolt 2 X M6 Nut 2 X J Bolt 1 X Universal Top Mount
LOCATION
PSR

**FITTING INSTRUCTIONS**

The cradle fits passenger side rear.

The charcoal canister has to be moved to the opposite side, and vacuum hoses lengthened. Remove appropriate insulation on fire wall so cradle sits on the metal guard. The wiring loom needs to be moved to fit in the cradle. Make sure the loom is not severely squashed when installing the cradle. One bolt on the lower left guard has to be removed and reused to fasten the cradle. Next, bolt the left hand brace with M6 bolts, where the charcoal canister used to be. The top supports need to be drilled with a right angle drill. Fasten with M6 nuts and bolts.

**NOTE: If ABS is fitted, the canister bracket needs to be modified so that it fits off the J bolt on the main battery (near radiator). IF ABS FITTED, NOT SUITABLE FOR SELF FIT.**



**MITSUBISHI PAJERO NH-NL**  
6G72 3.0 L Petrol/4D56-4.5 LD/4D56T-4.5TD  
WITH DUAL AIR CON

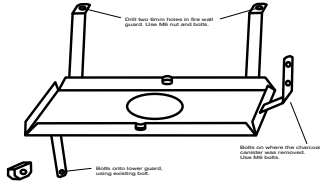

**FITTING INSTRUCTIONS**

<b>PART NUMBER</b>	BTMPN10
<b>BATTERY SIZE</b>	10 inch - ED50
<b>APPROX. FITTING TIME</b>	1 hour
<b>INCLUDED</b>	4 X M6 BOLT 2 X M6 NUT 2 X J BOLT 1 X Universal Top Mount
<b>LOCATION</b>	PSR

The cradle fits passenger side rear.  
The charcoal canister has to be moved to the opposite side, and vacuum hoses lengthened. Remove appropriate insulation on fire wall so cradle sits on the metal guard. The wiring loom needs to be moved to fit in the cradle. Make sure the loom is not severely squashed when installing the cradle. One bolt on the lower left guard has to be removed and reused to fasten the cradle. Next, bolt the left hand brace with M6 bolts, where the charcoal canister used to be. The top supports need to be drilled with a right angle drill. Fasten with M6 nuts and bolts.

**NOTE: If ABS is fitted, the canister bracket needs to be modified so that it fits off the J bolt on the main battery (near radiator). IF ABS FITTED, NOT SUITABLE FOR SELF FIT.**



NOT SUITABLE FOR SELF FIT  
IF ABS IS FITTED



APPROVED FOR SELF FIT

**MITSUBISHI PAJERO NM-NS**  
4M41 DID 3.2LD & 6G74 3.5L V6 PETROL



**FITTING INSTRUCTIONS**

<b>PART NUMBER</b>	BTMPNM
<b>BATTERY SIZE</b>	10 inch -ED50
<b>APPROX. FITTING TIME</b>	1 hour
<b>INCLUDED</b>	3 X M6 Bolt 3 X M6 Nut 2 X Body Washer 2 X Weld Bolt 1 X M6 Bolt Long 1 X M6 Nut 1 X Universal Top Mount 2 X J Bolts 1 X Cruise control Bracket
<b>LOCATION</b>	PSR

The cradle fits on passenger side rear.  
The charcoal canister has to be moved to the opposite side, and vacuum hoses lengthened. Unbolt cruise control unit. Mount cruise control unit onto tray first, then fit tray.

**NOTE: Caution should be taken to air conditioning piping.**



NOT SUITABLE FOR SELF FIT

**MITSUBISHI TRITON MH**  
6G7 2-3.0L V6 PETROL

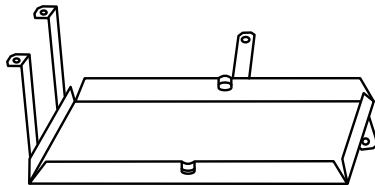

**FITTING INSTRUCTIONS**

<b>PART NUMBER</b>	BTMTP
<b>BATTERY SIZE</b>	12 inch- ED5
<b>APPROX. FITTING TIME</b>	1 hour
<b>INCLUDED</b>	4 X M6 Bolt 4 X M6 Nut 2 X Body Washer 2 X J Bolt 1 X Universal Top Mount
<b>LOCATION</b>	PSR

The cradle fits passenger side rear.  
Brake line modification may be required. We recommend the use of a heat shield between the battery and exhaust. We also advise an extra bracket from J bolt to outer skirt.



NOT SUITABLE FOR SELF FIT

**MITSUBISHI TRITON MH**  
4D56.2.5LD / 4D56T2.5TD

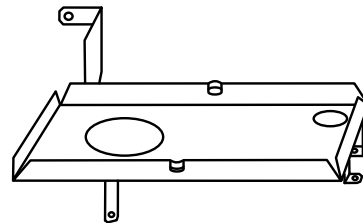

**FITTING INSTRUCTIONS**

<b>PART NUMBER</b>	BTMTD
<b>BATTERY SIZE</b>	12 inch- ED5
<b>APPROX. FITTING TIME</b>	1/2 hour
<b>INCLUDED</b>	2 X M6 Bolt 2 X M6 Nut 2 X Body Washer 2 X J Bolt 1 X Universal Top Mount
<b>LOCATION</b>	DSF

The cradle fits drivers side front.  
The tray sits east-west and takes a 12 inch case battery. The tray uses two original bolts. The other two should be marked and drilled. This tray takes about 30-40 minutes to fit.



APPROVED FOR SELF FIT



**MITSUBISHI TRITON**  
4M40 2.8 LD 3.0 V6 PETROL

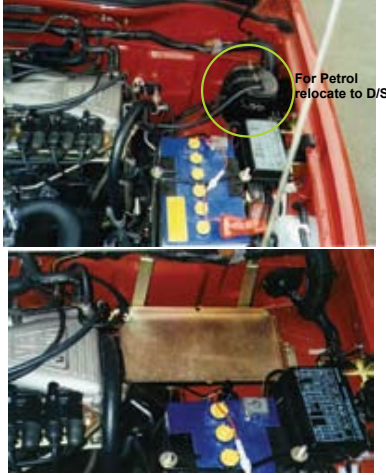

For Petrol relocate to D/S

<b>PART NUMBER</b>	BTMT28D
<b>BATTERY SIZE</b>	12 inch - ED5
<b>APPROX. FITTING TIME</b>	1 hour
<b>INCLUDED</b>	5 X M6 Bolt 5 X M6 Nut 3 X Body Washer 2 X J Bolt 1 X Universal Top Mount
<b>LOCATION</b>	PSR

**FITTING INSTRUCTIONS**

The cradle fits on the passengers side rear.

The arm going down sits on the inner skirt. There is normally nothing to relocate on this vehicle - Diesel Only. Five M6 nuts and bolts are supplied. Three panel washers are used. One for the lower support arm, and the other two are for the passenger side mount, used under the skirt. A hold down is also supplied.

**NOTE: Also suits Mitsubishi Triton petrol 97 BTMP97 (with diff. bolt kit - charcoal canister relocates to DHS)**



**MITSUBISHI TRITON MK**  
4M40 2.8 L TDI

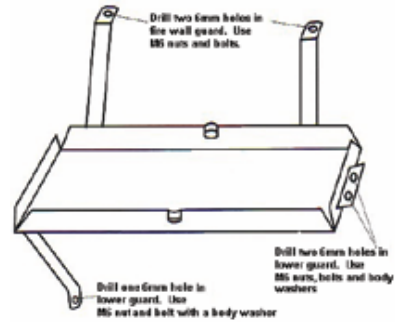

<b>PART NUMBER</b>	BTMT04
<b>BATTERY SIZE</b>	8 inch - ED4
<b>APPROX. FITTING TIME</b>	1 hour
<b>INCLUDED</b>	1 x Tray 5 x M6 Bolts 5 x M6 Nuts 3 x Body Washers 1 x Universal Top Mount 2 x J Bolt
<b>LOCATION</b>	PSR

**FITTING INSTRUCTIONS**

The cradle fits on the passenger side rear corner, with the two arms sitting on the lip of the fire wall.

The arm going down sits on the inner skirt. There is normally nothing to relocate on this vehicle. Five M6 nuts and bolts are supplied. Three panel washers are used, one for the lower support arm, and the remaining two for the passenger side mount, used under the skirt. A hold down is also supplied.



**MITSUBISHI ML TRITON**  
3.2L TD & 4 CYL PETROL



DELETED - USE BTMTV6

<b>PART NUMBER</b>	BTMTD06
<b>BATTERY SIZE</b>	8 inch - ED4
<b>APPROX. FITTING TIME</b>	1 hour
<b>INCLUDED</b>	1 x Tray 2 x M6 Nut 2 x M8 Bolt long 1 x M8 Body washer 1 x M8 Nut 1 x M6 Hex 1 x M6 Body Washer 1 x Universal Top Mount 2 x J Bolt
<b>LOCATION</b>	PSR

**FITTING INSTRUCTIONS**

The cradle fits on the passenger side rear.

Remove bracket on firewall (bolts holding lines)  
Place tray in position ensuring bottom bracket on tray fits onto the inner guard.  
Bolt top arms in top arms using bolts that were removed out of bracket.  
Nut onto thread to hold down bottom bracket.  
M6 bolt top arm lines up with hole in lower inner guard bolt  
making sure a body washer is used in mudguard / arch.



**MITSUBISHI TRITON ML**  
G74 3.5 L V6 EFI PETROL



<b>PART NUMBER</b>	BTMTV6
<b>BATTERY SIZE</b>	8 inch & 12 inch ED5
<b>APPROX. FITTING TIME</b>	1 hour
<b>INCLUDED</b>	1 x Tray 2 x M6 Hex 2 x M6 Washers 1 x Standard top mounts 1 x M8 Bolt Long 1 x M8 Short 1 x 600mm Vacuum Hose 2 x J Bolt
<b>LOCATION</b>	PSM

**FITTING INSTRUCTIONS**

The cradle fits passenger side middle, replacement of original tray.

Remove battery & existing plastic cradle.  
Remove bracket & clips that holds existing loom onto inner guard.  
Remove 13mm vacuum hose from engine and vacuum canister.  
Loom and hoses below vacuum canister need to be re-routed towards firewall.  
Slide tray under loom into position and using M6, bolt into captive next dipstick.  
Using M8 short, bolt into bracket on firewall.  
M6 bolts then bolt into remaining supports ensuring M6 body washers and nuts under guards.  
Place aux battery in rear of tray.  
When placing in original battery run wiring and new lengthened 13mm vacuum hose between the two batteries



**MITSUBISHI CHALLENGER**  
3.0 L V6 EFI 4 CYL PETROL



<b>PART NUMBER</b>
BTMCH
<b>BATTERY SIZE</b>
10 inch - ED50
<b>APPROX. FITTING TIME</b>
1 hour
<b>INCLUDED</b>
3 X M6 Bolt
5 X M6 Nut
3 X Body Washer
2 X Weld Bolts
2 X J Bolts
1 X Universal Top Mount
<b>LOCATION</b>
PSR

**FITTING INSTRUCTIONS**

The cradle fits in the left hand rear corner.

The two long arms fit onto lip of firewall. Two M6 weld bolts with body washers fit through side of tray to inner guard. Lower arm has to be bolted on.

**NOTE: MAY REQUIRE BRACKET TO BE REMOVED BY DRILLING OUT SPOT WELDS ON SOME MODELS.**

**CAN NOT BE FITTED TO VEHICLE WITH ABS**



**MITSUBISHI CHALLENGER**  
3.0 I V6 EFI 2003 PETROL



**FITTING INSTRUCTIONS**

This tray fits passenger side rear.

Unbolt carbon canister and cruise control unit. Carbon canister is relocated to front passenger side between radiator and air con receiver dryer. Use M6 nut and bolt through top of canister bracket and bolt through original hole in panel. Mark position for second bolt 60mm directly under top bolt and drill M6 hole. Place three packers on a long M6 bolt with panel washer and place in position and secure. Carbon canister lines need to be changed, provided in kit, cable tie neatly in position.

**NOTE: CAN NOT BE FITTED TO VEHICLE WITH ABS**



**MITSUBISHI CHALLENGER**  
3.0 I V6 EFI 2003 PETROL  
CONTINUED.....



<b>PART NUMBER</b>
BTMCH03
<b>BATTERY SIZE</b>
10 inch - ED50
<b>APPROX. FITTING TIME</b>
1 1/2 hour
<b>INCLUDED</b>
1 X Tray
4 X M6 Bolts
7 X M6 Nuts
3 X Packers
4 X Panel Washers
300mm Large hose
1 X Universal top mount
1 X M6 Long bolt
2 X J Bolt
2 R small hose
8/10 mm small vacuum hose
1 X M6 bolt
<b>LOCATION</b>
PSR

Cruise control unit is secured onto bracket, provided, then bolted to inlet manifold, (Ref Pic), using the original three self tapper screws, standard bracket is not used.

Untape original wiring loom where cruise control unit joins in and pull wiring through to reach new position of cruise control unit.

Place tray into position, cut insulation from fire wall where tray mounts, mark and drill holes, Bolt tray into position.



**MAZDA B2500 DIESEL**  
2.5 D & 2.5 TDI

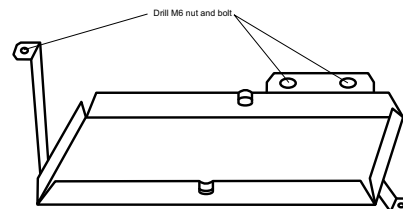

<b>PART NUMBER</b>
BTM25
<b>BATTERY SIZE</b>
8 inch - ED4
<b>APPROX. FITTING TIME</b>
1 hour
<b>INCLUDED</b>
3 X M6 Bolt (not sunk)
4 X M6 Bolts
4 X M6 Nut
3 X Body Washer
2 X J Bolt
<b>LOCATION</b>
PSR

**FITTING INSTRUCTIONS**

The cradle fits passenger side rear.

The long arm fits on the fire wall lip with a 6mm nut and bolt. The small bracket on the outer side of the tray with two holes in it should fit flush against the guard. Drill two holes and fasten with 2 x 6mm nuts and bolts, using body washers under the guard. Mark and drill the arm going down to the guard and again use the bolts supplied. A heat shield may be required for the side of the battery.



**MAZDA B2600/ FORD COURIER**  
2.6 L PETROL CARBY

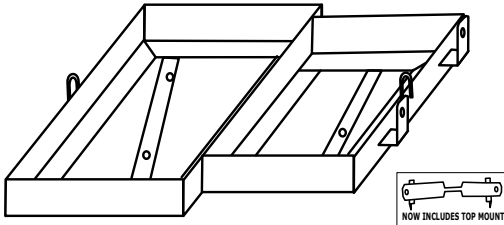

<b>PART NUMBER</b>	BTMBC
<b>BATTERY SIZE</b>	ORIG. +8 inch ED4
<b>APPROX. FITTING TIME</b>	1 hour
<b>INCLUDED</b>	3 X M8 Bolt (not sunk) 2 X M8 Bolt short 2 X J Bolt 1 X Special Top Mount
<b>LOCATION</b>	PSFT

**FITTING INSTRUCTIONS**

The cradle fits passenger side, replacing the existing tray. Check to make sure that the original lower support bracket is in sound condition. If the bracket is cracked, fix it first before continuing with the cradle installation. The dual cradle utilises the original captive nuts in the lower bracket. Six M8 bolts hold the cradle in position. Sometimes the radiator support bracket has to be modified, so that the dual cradle can be installed. Two battery hold downs are provided.



**MAZDA B2600/ FORD COURIER**  
2.6 L PETROL EFI

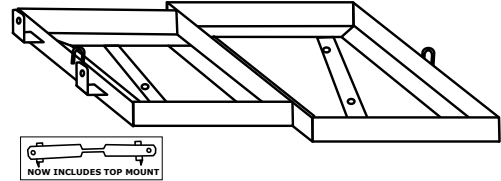

<b>PART NUMBER</b>	BTMBI
<b>BATTERY SIZE</b>	ORIG. +8 inch ED4
<b>APPROX. FITTING TIME</b>	1 hour
<b>INCLUDED</b>	3 X M8 Bolt (not sunk) 2 X M8 Bolt short 2 X J Bolt 1 X Special Top Mount
<b>LOCATION</b>	DSFT

**FITTING INSTRUCTIONS**

The cradle fits drivers side front replacing the existing tray. Check to make sure that the original lower support bracket is in sound condition. If the bracket is cracked, fix it first before continuing with the cradle installation. The dual cradle utilises the original captive nuts in the lower bracket. Six M8 bolts hold the cradle in position. Sometimes the radiator support bracket has to be modified, so that the dual cradle can be installed. Two battery hold downs are provided.



**1999 MAZDA BRAVO FORD COURIER**  
4 CYL EFI PETROL

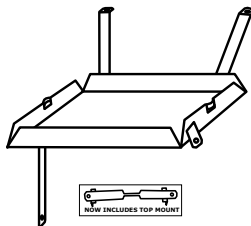

<b>PART NUMBER</b>	BTMP99
<b>BATTERY SIZE</b>	8 inch - ED4
<b>APPROX. FITTING TIME</b>	1 hour
<b>INCLUDED</b>	4 X M6 BOLT 3 X M6 NUT 1 X BODY WASHER 2 X J BOLT 1 X Standard Top Mount
<b>LOCATION</b>	PSR

**FITTING INSTRUCTIONS**

The cradle fits passenger side rear. This tray fits in easily, no relocation required. Top mount supplied.



**1999 MAZDA BRAVO/FORD COURIER**  
4 CYL TDI

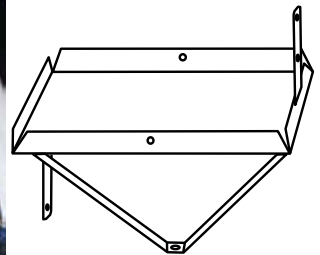

<b>PART NUMBER</b>	BTMTDI
<b>BATTERY SIZE</b>	10 inch - ED50
<b>APPROX. FITTING TIME</b>	1 hour
<b>INCLUDED</b>	4 X M6 BOLT 1 X M6 NUT 1 X BODY WASHER 1 X M8 BOLT SHORT 2 X J BOLT 1 X Special Top Mount
<b>LOCATION</b>	PSF

**FITTING INSTRUCTIONS**

The cradle fits passenger side front. Nothing to relocate, top mount supplied.





**MAZDA B50/FORD RANGER**  
4 Cyl TDI ( Manual)

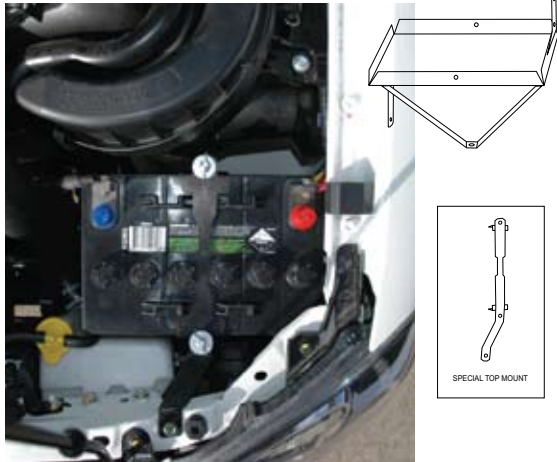

<b>PART NUMBER</b>
BTMB50TDI
<b>BATTERY SIZE</b>
10 inch - ED50
<b>APPROX. FITTING TIME</b>
1 hour
<b>INCLUDED</b>
1 X M8 BOLT LONG
3 X M8 HEX
1 X M6 Nut
2 X J BOLT
1 X Special Top Mount
<b>LOCATION</b>
PSF

**FITTING INSTRUCTIONS**

The cradle fits passenger side front.

This takes a 10in case battery eg. EXIDE ED50 65amp/hour  
Fits in the corner behind the headlight on the passenger side.

Remove rear bolt from flat in-between head light & air cleaner  
Move wiring loom from same position  
Place tray in position (air conditioning pipe may need to be moved)  
Place M8 bolt into captive below air conditioning pipe  
Replace bolt through bottom bracket into guard  
Place two M6 bolts in upper bracket into captives  
Place battery in tray  
Line up top mount and drill hole in radiator support  
Fit M6 bolt nut through this hole



**MAZDA B50/FORD RANGER**  
4 Cyl TDI (Auto Only)



<b>PART NUMBER</b>
BTMB50TDIA
<b>BATTERY SIZE</b>
10 inch - ED50
<b>APPROX. FITTING TIME</b>
½ hour
<b>INCLUDED</b>
3 x M8 Hex
1 x Crank M6
1 x M8 Body washer
2 x Spacers
3 x M6 Nut
<b>LOCATION</b>
PSF

**FITTING INSTRUCTIONS – FOR AUTO COMPUTER**

The cradle fits passenger side front

Remove computer mounting bracket from inner guard.  
Remove wiring and relay from bracket.  
Remove computer from bracket by removing 2 M6 nuts and removing hold down bracket.  
Cut hold down bracket as shown. (1)  
Bolt computer bracket and heat shield behind air cleaner using one existing hole and drilling rear hole to suit. (2)  
(brake line will have to be modified.)  
Re-run wiring and computer to new position and using hold down bracket bolt in.  
Replace M6 Bolt in the top of guard with longer M6 and spacers.  
Place two braces on computer bracket.  
Brace bolts to heat shield



**MAZDA BRAVO/ FORD COURIER**  
4.0L V6 EFI PETROL

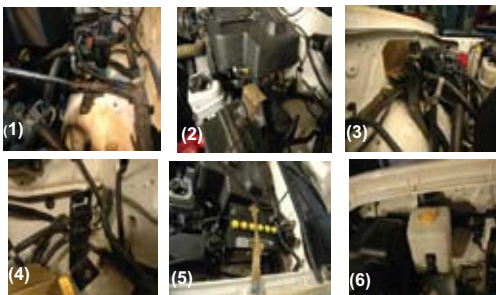

**FITTING INSTRUCTIONS**

The cradle fits passenger side rear.

<b>PART NUMBER</b>
BTMBV6P
<b>BATTERY SIZE</b>
8 inch - ED4
<b>APPROX. FITTING TIME</b>
2 hour
<b>INCLUDED</b>
1 X Tray
2 X Fuse Box Mount
1 X Top Mount
7 X M8 Short Hex
2 X M8 Long
4 X Black spacer washer
2 X M8 Cr Sunk
6 X M6 Nut
2 X M8 Body Washer
1 X PS Spacer
1 X Special Top Mount
<b>LOCATION</b>
PSR

Remove washer bottle & mount.  
Unbolt fuse box & vacuum valves  
Remove Fuse Box Bracket  
Move loom to front of other bracket (1)  
Move Fuse box to in between original battery and bracket  
Bolt bracket closest to motor on fuse box (2)  
Insert bolt to existing bracket with spacer in hole on bracket (3)  
Bolt bracket between fuse box & inner guard & tighten  
Place tray in & Bolt  
Conduit A/C line (20mm) and mount vacuum valves on existing bracket / Cut down. (4)  
Place Battery in tray (5)  
Top mount aligns with bolt on guard (use longer bolt provided)  
Bend Original washer mount to fit drivers side (6)  
Using P.S. Spacer bolt to captive.  
Extend wiring to drivers side



**F100/F150/BRONCO**  
V8 PETROL

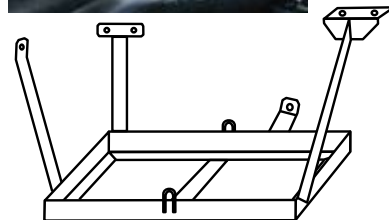

<b>PART NUMBER</b>
BTF100
<b>BATTERY SIZE</b>
12 inch - ED5
<b>APPROX. FITTING TIME</b>
1 hour
<b>INCLUDED</b>
2 X M6 NUT
2 X M8 WELDBOLT
1 X M8 BOLT SHORT
1 X M6 NUT
2 X J BOLT
1 X Universal Top Mount
<b>LOCATION</b>
PSR

**FITTING INSTRUCTIONS**

The cradle fits passenger side rear.

With plastic mud guard it looks flimsy however, it is strong. The battery sits slightly on an angle, this is correct. Fitting is not simple as body washers are required.



## FORD F250 / BRONCO

### 6 Cyl V8 PETROL / DIESEL

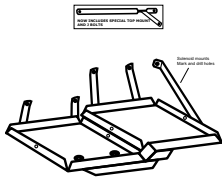

<b>PART NUMBER</b>
BTF250
<b>BATTERY SIZE</b>
12 inch + 12 inch ED5
<b>APPROX. FITTING TIME</b>
1 hour
<b>INCLUDED</b>
3 X M6 BOLT
2 X M6 NUT
2 X M6 WELD BOLT
2 X M8 BOLT SHORT
2 X M8 BOLT (one side)
1 X M6 NUT
2 X J BOLT
1 X Special Top Mount
<b>LOCATION</b>
DSFT

#### FITTING INSTRUCTIONS

The cradle fits drivers side front.

Take out single factory fitted tray and fit double. Fits V8 petrol, V8 Diesel, 6 cyl turbo diesel all models. Move fuse block to between loom/air intake pipe. Relocate solenoid to largest arm of tray. Lugs one side of original battery cut off very carefully. main goes to rear, aux to front.



## FORD EXPLORER

### V6 PETROL

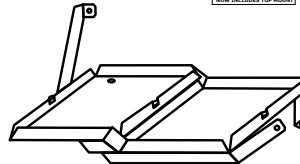

<b>PART NUMBER</b>
BTFEX
<b>BATTERY SIZE</b>
8 inch + Narrow ED10S
<b>APPROX. FITTING TIME</b>
1 hour
<b>INCLUDED</b>
1 X M6 BOLT (one side)
1 X M6 NUT
1 X BODY WASHER
2 X J BOLT
1 X Special Top Mount
<b>LOCATION</b>
PSFT

#### FITTING INSTRUCTIONS

The cradle fits passenger side front.

Remove the original plastic tray and replace it with the dual cradle. The large original battery will have to be replaced with two smaller batteries. They are an AMF 520 and a 43T deep cycle. You use all original bolts, except one, for this tray.

**NOTE: Special top mount must be used.**



## HOLDEN JACKAROO

### 4CYL PETROL/DIESEL

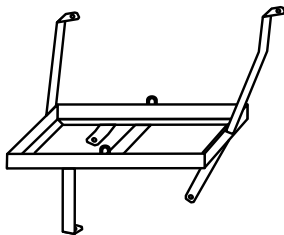

<b>PART NUMBER</b>
BTHJO
<b>BATTERY SIZE</b>
8 inch - ED4
<b>APPROX. FITTING TIME</b>
1 hour
<b>INCLUDED</b>
5 X M6 BOLT
4 X M6 NUT
2 X BODY WASHER
2 X J BOLT
1 X Universal Top Mount
<b>LOCATION</b>
PSR

#### FITTING INSTRUCTIONS

The cradle fits passenger side rear.

Fits on existing bolt holes.

**Warning: This is a very tight fit and there is very low clearance to the bonnet. A recessed terminal battery is required.**



## HOLDEN JACKAROO

### 3.2 I V6/3.5L V6 ('92 - '99 8" Battery)



<b>PART NUMBER</b>
BTHJS
<b>BATTERY SIZE</b>
8 inch - ED4
<b>APPROX. FITTING TIME</b>
2 hours
<b>INCLUDED</b>
3 X M6 BOLT
1 X M6 BOLT (one side)
4 X M6 NUT
2 X BODY WASHER
1 X M8 BOLT SHORT
2 X J BOLT
1 X Universal Top Mount
<b>LOCATION</b>
PSR

#### FITTING INSTRUCTIONS

The cradle fits passenger side rear.

Air conditioning pipes will foul cradle on all models. They may require degassing, remounting and re-gassing. Brake lines will also need minor modification. If the tray is fitted to a diesel vehicle, there is no further modification needed. If the tray is being fitted to a V6 injected vehicle, the charcoal canister relocates on the other side, behind the main battery, with modification to the original bracket. The metal pipe along the fire wall can now be removed. Reconnect air hoses. If cruise control is fitted, it will have to be remounted. The radiator overflow bottle also has to be moved, so that it sits parallel with the secondary battery. An L-bracket needs to be made up, so that it mounts on the left hand skirt rail. The lower mount of the bottle picks up an original tapped hole (beneath the cradle). The looms have to be moved out of the way.





## HOLDEN JACKAROO 3.5 L V6/3.2L V6 (1992-1999)



PART NUMBER
BTHJN
BATTERY SIZE
12 inch - ED5
APPROX. FITTING TIME
2 hours
INCLUDED
3 X M6 BOLT 1 X M6 BOLT (see note) 4 X M6 NUT 2 X BODY WASHER 2 X J BOLT 1 X Standard Top Mount
LOCATION
PSR

### FITTING INSTRUCTIONS

The cradle fits passenger side rear.

Air conditioning pipes will foul cradle on all models. They may require degassing, remounting and re-gassing. Brake lines will also need minor modification. If the tray is fitted to a diesel vehicle, there is no further modification needed. If the tray is being fitted to a V6 injected vehicle, the charcoal canister relocates on the other side, behind the main battery, with modification to the original bracket. The metal pipe along the fire wall can now be removed. Reconnect air hoses. If cruise control is fitted, it will have to be remounted. The radiator overflow bottle also has to be moved, so that it sits parallel with the secondary battery. An L-bracket needs to be made up, so that it mounts on the left hand skirt rail. The lower mount of the bottle picks up an original tapped hole (beneath the cradle). The looms have to be moved out of the way.



## HOLDEN JACKAROO 1999 Onwards 4 Cyl EFI TDI

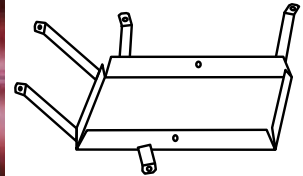

PART NUMBER
BTHJ99D
BATTERY SIZE
12 inch - ED5
APPROX. FITTING TIME
1 hour
INCLUDED
5 X M6 BOLT 3 X M6 NUT 1 X BODY WASHER 2 X J BOLT 1 X Special Top Mount
LOCATION
PSR

### FITTING INSTRUCTIONS

The cradle fits passenger side rear.

No Modifications required.  
Special top mount supplied.



## HOLDEN RODEO "98-"02 4JB-1T 2.8 L TD & V6 PETROL



PART NUMBER
BTHRD
BATTERY SIZE
8 inch - ED4
APPROX. FITTING TIME
1 hour
INCLUDED
3 X M6 BOLT 1 X M6 BOLT (see note) 1 X M6 NUT 1 X BODY WASHER 1 X M6 BOLT SHORT 2 X J BOLT 1 X Universal Top Mount
LOCATION
DSF

### FITTING INSTRUCTIONS

The cradle fits drivers side front.

The cradle faces east west. The long arm of the tray mounts up beside the overflow bottle. You will have to move and relocate the diesel filter and power steering fluid reservoir. This can be done by modifying the original bracket and bolting it to the inner skirt. Once these have been moved, the tray is very simple to fit. As before, place the long arm beside the overflow bottle, then the three brackets going down should rest on the skirt. Mark, and drill the required holes. Use the nuts and bolts provided to fasten down the tray.  
**Note - the air conditioning lines may have to be bent out of the way, very carefully. (Note, this is not an easy cradle to fit).**



## HOLDEN RODEO 2002 DIESEL

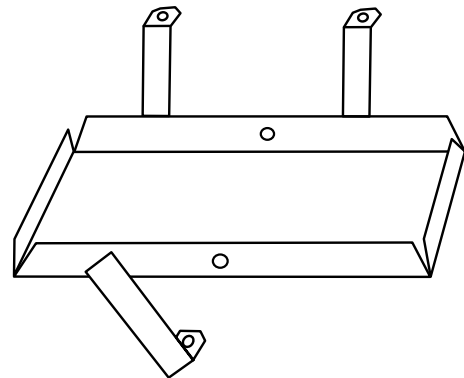

PART NUMBER
BTHRD02
BATTERY SIZE
8 inch - ED4
APPROX. FITTING TIME
1 hour
INCLUDED
1 X Tray 3 X M6 BOLT 1 X M6 BOLT (see note) 1 X Universal top mount 4 X M6 Nut 2 X Body washer 2 X J Bolts
LOCATION
PSR

### FITTING INSTRUCTIONS

The cradle fits passenger side rear.

Unclip main wiring loom from fuel filter support. Place tray into position and mark mounting holes, remove tray and drill holes. Refit tray and bolt in position, tie wiring loom to tray bracket.

**NOTE: Take care to keep air conditioner lines away from tray - do not allow them to rub on tray.**



## HOLDEN RODEO 2003

### 3.0 L V6 PETROL / DIESEL NON ABS



<b>PART NUMBER</b>
BTHRD03
<b>BATTERY SIZE</b>
8 inch - ED4
<b>APPROX. FITTING TIME</b>
1 hour
<b>INCLUDED</b>
1 x Tray 6 x M6 Bolt 4 x Panel washer 1 x Universal top mount 4 x M6 nut 1 x M6 bolt long 2 x J Bolt
<b>LOCATION</b>
PSR

#### FITTING INSTRUCTIONS

The cradle fits passenger side rear.

Remove Power steering reservoir, and cruise control unit (if fitted). Place tray into position. Place Power Steering reservoir into position between tray and original battery, drill holes to secure bracket. Bolt Power steering reservoir in place and then tray in place. Drill front left-hand mount hole and bolt in place. Place Cruise control (if fitted) on drivers' side guard and extend wiring and vacuum hose.



## HOLDEN RODEO 2006

### 3.0 L DIESEL



<b>PART NUMBER</b>
BTHRD06
<b>BATTERY SIZE</b>
10 inch - ED50
<b>APPROX. FITTING TIME</b>
1 1/2 hour
<b>INCLUDED</b>
1 x Tray 3 x M6 Bolt - Hex 3 x M6 Nuts 1x Standard top mount 2 x M6 C/Sunk 2 x M6 body washers 2 x J Bolts
<b>LOCATION</b>
PSR

#### FITTING INSTRUCTIONS

The cradle fits passenger side rear.

Remove power steering reservoir & unbolt mount. Drill out spot weld on bottom of mount. Place tray into position & bolt rear corner. Bolt lower arm & additional 2 bolts in inner guard. Bolt with c/sunk power steering reservoir to brackets on corner of tray. Place battery in tray. Fit top mount & secure.



## HOLDEN RODEO 2006

### V6 EFI PETROL WITH / WITHOUT ABS

#### TWIN EXIDE ED10 OPTION



<b>PART NUMBER</b>
BTHRP06/E
<b>BATTERY SIZE</b>
2 X Narrow ED10S
<b>APPROX. FITTING TIME</b>
1 hour
<b>INCLUDED</b>
1 x Tray 5 x M6 nuts 8 x M6 bolts 1 x M6 washer 1 x special top mount 1x backup plate 1 x 6M Ctr Sunk Bolt 2 x J Bolts
<b>LOCATION</b>
DSRT

#### FITTING INSTRUCTIONS

The cradle fits drivers side rear.

Remove radiator overflow bottle and remount, using supplied brackets, behind drivers side head light. Bottom mount bolts under front air cleaner leg, top bracket attaches to radiator overflow bottle, drill hole in radiator support panel and secure. Cut and reconnect hose.

Remove bracket holding the three (3) break lines, discard metal section, plastic separator is to be reused. Place tray into position and loosely bolt into existing captive points, wiring may need to be unclipped and moved. Three remaining holes to be drilled, one on firewall two under socket holes, use supplied back up plate under guard to reinforce tray under socket holes, bolt into position. Tighten all nuts and bolts securely.

**NOTE:** Secure battery in position using top mount, carefully, by hand, bend brake and air-conditioner lines ensuring they DO NOT rub battery, reposition plastic separator clip.



## HOLDEN RODEO 2006

### V6 EFI PETROL WITH / WITHOUT ABS

#### OPTIMA BATTERY OPTION



<b>PART NUMBER</b>
BTHRP06/O
<b>BATTERY SIZE</b>
10 inch - ED50
<b>APPROX. FITTING TIME</b>
1 hour
<b>INCLUDED</b>
1 x Tray 6x M6 Bolts 6 x M6 nuts 1 x universal top mount 1 x backup plate 1 x 6 M Ctr sunk bolts 2 x J Bolts
<b>LOCATION</b>
DSR

#### FITTING INSTRUCTIONS

The cradle fits drivers side rear.

Remove radiator overflow bottle and remount, using supplied brackets, behind driver's side head light. Bottom mount bolts under front air cleaner leg, top bracket attaches to radiator overflow bottle, drill hole in radiator support panel and secure. Cut and reconnect hose.

Remove master cylinder brackets, these need to be reused and trimmed approx 20mm, to clear the battery brackets.

Place tray into position and bolt into existing captive points, two remaining holes to be drilled, using supplied back up plate under guard, bolt into position.

**NOTE:** Secure battery in position using top mount, carefully, by hand, bend brake and air-conditioner lines ensuring they DO NOT rub battery.



## HOLDEN RODEO 2007 RA 3.0 VCDI



<b>PART NUMBER</b>
BTHRD07
<b>BATTERY SIZE</b>
8 inch - ED4
<b>APPROX. FITTING TIME</b>
1 hour
<b>INCLUDED</b>
1 x Tray 6 x M6 Bolt - Hex 3 x M6 Nuts 2 x Weld bolts 1x Standard top mount 1 x special right angle bracket 2 x J Bolts
<b>LOCATION</b>
PSR

### FITTING INSTRUCTIONS

The cradle fits passenger side rear.

Unbolt power steering Reservoir Bracket & Drill out two bottom spot welds. (Pic 2)  
Remove Breather & drain plug from bracket & remove bracket. Mount power steering reservoir bracket to tray using M6 Nuts & weld bolts x 2. (Pic 4)  
Place tray into position (A/C line may need tweaking) and bolt in 3 M6 Top bolts, then 4th M6 down the bottom of the inner guard. Using right angle bracket re-attach breather & drain plug to inner guard. (Lines may need slight manipulating)



**NOT SUITABLE FOR SELF FIT**

## HOLDEN FRONTERA 4CYL PETROL

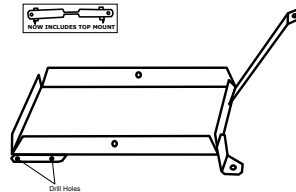
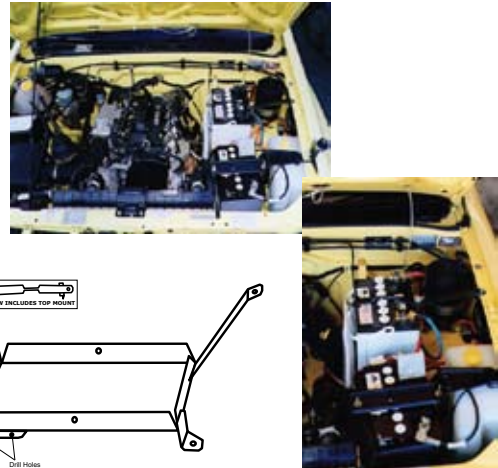

<b>PART NUMBER</b>
BTHF
<b>BATTERY SIZE</b>
8 inch - ED4
<b>APPROX. FITTING TIME</b>
1 hour
<b>INCLUDED</b>
4 X M6 BOLT 5 X M6 NUT 3 X BODY WASHER 1 X M6 BOLT LONG 2 X J BOLT 1 X Universal Top Mount
<b>LOCATION</b>
PSM

### CRADLE FITTING INSTRUCTIONS

The cradle fits passenger middle.

Drill holes to guard, use nuts, bolts and washers as supplied. It is a tight fit. The air conditioning pipe and wiring loom require minor relocation. Brackets on side of original tray need modification.



**APPROVED FOR SELF FIT**

## HOLDEN FRONTERA V6 PETROL

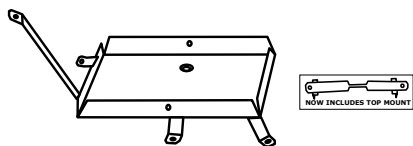

<b>PART NUMBER</b>
BTHFV6
<b>BATTERY SIZE</b>
8 inch - ED4
<b>APPROX. FITTING TIME</b>
1 hour
<b>INCLUDED</b>
4 X M6 BOLT 4 X M6 NUT 3 X BODY WASHER 2 X J BOLT 1 X Universal Top Mount
<b>LOCATION</b>
PSM

### CRADLE FITTING INSTRUCTIONS

The cradle fits passenger side middle.

Locates to existing bolts. Drill holes to guard and bolt as supplied. It is a tight fit. The air conditioning pipe and wiring loom require minor relocation.



**NOT SUITABLE FOR SELF FIT**

## SUZUKI SIERRA 1.0 L PETROL



Drill two 6mm holes into guard. Use M6 counter sunk bolts and nuts with body washers under the guard.

Drill two 6mm holes through the fire wall and holes bay with M6 nuts and bolts.

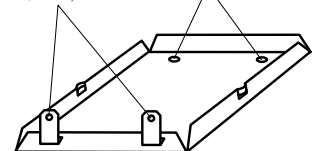

<b>PART NUMBER</b>
BTSS
<b>BATTERY SIZE</b>
8 inch - ED4
<b>APPROX. FITTING TIME</b>
1 hour
<b>INCLUDED</b>
2 X M6 BOLT 2 X M6 BOLT (cont. with) 4 X M6 NUT 2 X BODY WASHER 2 X J BOLT 1 X Universal Top Mount
<b>LOCATION</b>
PSR

### FITTING INSTRUCTIONS

The cradle fits passenger side rear.

The charcoal canister will need to be removed. Drill two 6mm holes through the fire wall for the two angle mounts. Use M6 bolts and nuts to fasten the two support braces onto the fire wall. The charcoal canister will need to be relocated first. Two holes have to be drilled into the lower guard, and fastened with M6 counter sunk bolts using nuts and body washers.

(Note: be careful of interior furnishings).



**APPROVED FOR SELF FIT**



**SUZUKI SIERRA**  
1.3L PETROL

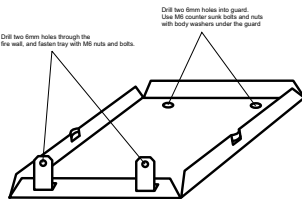

<b>PART NUMBER</b>
BTSS10
<b>BATTERY SIZE</b>
10 inch - ED50
<b>APPROX. FITTING TIME</b>
1 hour
<b>INCLUDED</b>
2 X M6 BOLT
2 X M6 BOLT (c/sk)
4 X M6 NUT
2 X BODY WASHER
2 X J BOLT
1 X Universal Top Mount
<b>LOCATION</b>
PSR

**FITTING INSTRUCTIONS**

The cradle fits passenger side rear.

The charcoal canister will need to be removed. Drill two 6mm holes through the fire wall for the two angle mounts. Use M6 bolts and nuts to fasten the two support braces onto the fire wall. The charcoal canister will need to be relocated first. Two holes have to be drilled into the lower guard, and fastened with M6 counter sunk bolts using nuts and body washers.

(Note: be careful of interior furnishings).



**SUZUKI VITARA**  
V6 PETROL

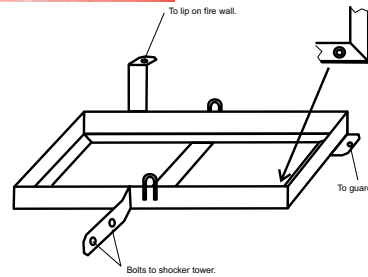

<b>PART NUMBER</b>
BTSV
<b>BATTERY SIZE</b>
8 inch - ED4
<b>APPROX. FITTING TIME</b>
1 hour
<b>INCLUDED</b>
4 X M6 BOLT
1 X M6 BOLT (c/sk)
5 X M6 NUT
2 X BODY WASHER
2 X J BOLT
1 X Universal Top Mount
<b>LOCATION</b>
PSR

**FITTING INSTRUCTIONS**

The cradle fits passenger side rear.

This is a 12 inch cradle but it only takes an 8 inch battery. This is to clear the wiper motor. Very simple to fit. The bolts to the shocker tower are fiddly to get to. Use a ring spanner and a W12 lock nut with collar.



**SUZUKI GRAND VITARA**  
V6 Petrol

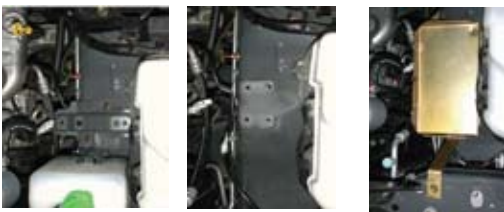

<b>PART NUMBER</b>
BTSGV
<b>BATTERY SIZE</b>
8 inch - ED4
<b>APPROX. FITTING TIME</b>
1 hour
<b>INCLUDED</b>
1 X Tray
3 X M6 Bolts
1 X M6 C/sk sunk bolts
1 X Universal top mounts
4 X M6 nut
2 X J Bolt
<b>LOCATION</b>
DSF

**FITTING INSTRUCTIONS**

The cradle fits drivers side rear.

Remove overflow bottle and drill out spot welds on overflow bracket. Place tray into position, line up lower front of bracket with original holes, drill out remaining holes.

Bolt tray into position. Overflow bottle is moved to drivers side front of vehicle. Modify overflow bracket to fit bottle in front of air cleaner.

NOTE: Battery terminal posts may need to be shortened to avoid touching the bonnet. Check bonnet clearance before closing.



**SUZUKI JIMNY**  
4 CYL EFI PETROL



<b>PART NUMBER</b>
BTSJI
<b>BATTERY SIZE</b>
8 inch - ED4
<b>APPROX. FITTING TIME</b>
1 hour
<b>INCLUDED</b>
1 X Tray
2 X M6 Bolts C/sk
1 X special top mounts
5 X M6 nut
3 X M6 bolts
3 X Panel washer
<b>LOCATION</b>
DSF

**FITTING INSTRUCTIONS**

The cradle fits drivers side rear.

Tray fits passenger side rear of engine bay, nothing to relocate. Top mount brace needs to be fitted.





**DAIHATSU FEROZA**  
4CYL PETROL

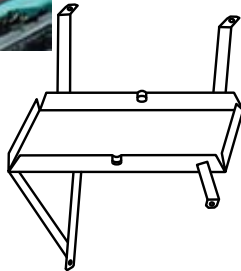

<b>PART NUMBER</b>
BTDF
<b>BATTERY SIZE</b>
8 inch - ED4
<b>APPROX. FITTING TIME</b>
1 hour
<b>INCLUDED</b>
4 X M6 BOLT (one each)
4 X M6 NUT
1 X BODY WASHER
2 X J BOLT
1 X Universal Top Mount
<b>LOCATION</b>
PSR

**FITTING INSTRUCTIONS**

The cradle fits passenger side rear  
No major problems to install.

**Note:** Tray might not fit if air conditioning fitted.



**DAIHATSU ROCKY**  
2.8 D / 4 CYL P

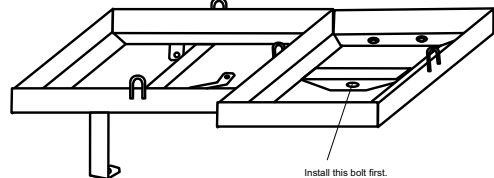

Install this bolt first.

<b>PART NUMBER</b>
BTDR
<b>BATTERY SIZE</b>
12 inch + 8 inch ED5 + ED4
<b>APPROX. FITTING TIME</b>
2 hours
<b>INCLUDED</b>
2 X M8 BOLT (one each)
2 X M6 NUT
2 X M8 BOLT SHORT
2 X M6 NUT
4 X J BOLT
2 X Universal Top Mount
<b>LOCATION</b>
PSMT

**FITTING INSTRUCTIONS**

The cradle fits drivers side middle replacing original tray  
Lines up on existing encapsulated nuts, uses M6 bolts.

**NOTE:** on diesel original battery will not fit.



**JEEP CHEROKEE SPORT**  
6 CYL EFI ORIGINAL

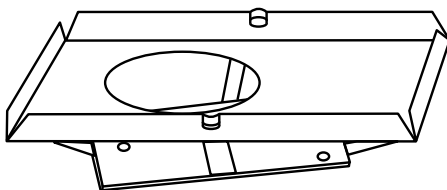

<b>PART NUMBER</b>
BTJCR
<b>BATTERY SIZE</b>
8 inch - ED4
<b>APPROX. FITTING TIME</b>
1 hour
<b>INCLUDED</b>
2 X J BOLT
1 X Universal Top Mount
<b>LOCATION</b>
DSF

**FITTING INSTRUCTIONS**

The cradle fits drivers side rear, remove original tray.

This cradle uses existing bolts. A hole may have to be drilled into cradle to take sensor.



**JEEP CHEROKEE SPORT**  
6 CYL- INLINE EFI

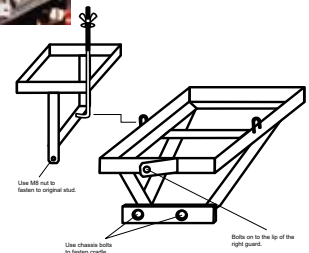

Use M8 nut to tighten to original stud.

Use chassis studs to fasten cradle.

Bolts on to the top of the right guard.

<b>PART NUMBER</b>
BTJCA
<b>BATTERY SIZE</b>
8 inch - ED4
<b>APPROX. FITTING TIME</b>
2 hours
<b>INCLUDED</b>
1 X M8 BOLT
2 X M6 NUT
1 X WELD BOLT
1 X M6 NUT
1 X J BOLT
1 X Universal Top Mount
<b>LOCATION</b>
DSM

**FITTING INSTRUCTIONS**

The cradle fits drivers side middle.

To install the Jeep cradle, remove washer bottle and bracket. Undo two chassis nuts below original washer bottle and one M8 bolt on the lip of the right guard. The cradle now fits in, locating the bottom plate on the chassis studs. The other tab on the cradle bolts on the right guard using the existing tapped hole. The new washer bottle bracket is located by the J-bolt on the cradle, and an existing M8 stud down under the brake booster. Fasten with M8 nut. If the stud is not present, drill a 6mm hole and use a 6mm weld bolt and nut. Re-direct the return radiator hose and power steering hoses, making sure they are not squashed or kinked.



## JEEP GRAND CHEROKEE 6 CYL- INLINE EFI

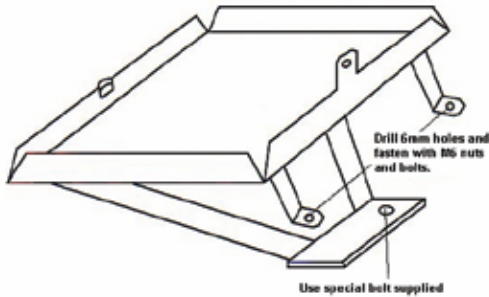

PART NUMBER
BTJCG
BATTERY SIZE
Narrow - ED10S
APPROX. FITTING TIME
1 hour
INCLUDED
2 X M6 BOLT
2 X M6 NUT
2 X BODY WASHER
1 X SPECIAL BOLT
2 X J BOLT
1 X Universal Top Mount
LOCATION
DSM

### FITTING INSTRUCTIONS

The cradle fits drivers side middle. (between the receiver drier and the cruise control, above the steering shaft.)  
The flat mount on the bottom of the tray sits flat on top of the chassis rail behind the engine mount. A special bolt is supplied for this. You may have to unbolt the cruise control unit, and on the bottom stud place a 10mm spacer, then replace the cruise control unit. This will kick the front of the unit up so it misses the battery. The two arms going down to the drivers side, sit on the skirt. Drill these once you have bolted the bottom bracket. Use two M6 nuts and bolts supplied. A right angle drill may be needed for the rear mount hole.



## JEEP KJ CHEROKEE 2.8 Diesel



### FITTING INSTRUCTIONS

This is a twin tray and fits passenger side front.

PART NUMBER
BTJKJD
BATTERY SIZE
8 + 8 Inch - ED4
APPROX. FITTING TIME
Up to 3 hrs
INCLUDED
1 x Tray
4 x M6 weld bolts
4 x M6 Nuts
2 x J Bolts
1 x Special Top Mount
Remainder of kit depends on fit of vehicle.
LOCATION
PSFT

Unbolt original battery, battery holder and fuse box, unplug battery sensor and remove tray.  
Place new tray into position using original mounting studs, tighten using original nuts. Fit battery sensor into counter sunk access hole on front of tray. Unbolt ECU from inner guard, manufacture a mounting bracket to come from edge of tray and bolt into position. Manufacture a second mounting bracket to house factory fuse box and position on inner guard.  
**NOTE: Ensure fuse box and wiring loom are clear of tray to prevent damage. Use vehicles original Earth for Aux. Battery and extend main power cable to reach front of tray.**

**WARNING: THIS TRAY IS EXTREMELY HARD TO FIT SOME PARTS REQUIRE FABRICATION. IT IS NOT FOR RESALE/SELF FIT AND ADVISE AGAINST ATTEMPTING UNLESS WORKSHOP IS EQUIPPED.**



## DEFENDER 3.5 P/2.5 TDI

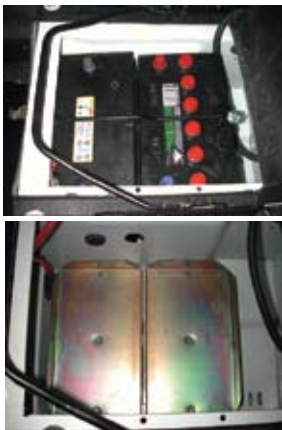

PART NUMBER
BTDEF
BATTERY SIZE
12 inch X 2 ED5
APPROX. FITTING TIME
1 hour
INCLUDED
2 X J Bolt
1 X Special Top Mount
6 X M6 Extra long Cnt Sunk
6 X M6 Nuts
6 X Body Washers
LOCATION
UPST

### FITTING INSTRUCTIONS

The cradle fits under the passenger seat. It allocates one tray for the original starting battery and a second for auxiliary. Spacer blocks are required to make the tray sit strong and flat.

Tray holds 12" case batteries, we suggest 10" batteries. Hold down will need to be manufactured to suit batteries.

**Note: The batteries are fiddly to install.**



## DEFENDER DURATECH ENGINE



PART NUMBER
BTDEFDT
BATTERY SIZE
Original + 10"
APPROX. FITTING TIME
1 hour
INCLUDED
2 X J Bolt
1 X Special Top Mount
4 X M6 Extra long Cnt Sunk
5 X M6 Nuts
5 X Body Washers
1 X Hex
LOCATION
UPST

### FITTING INSTRUCTIONS

The cradle fits under the passenger seat.

- Take out main battery
- Remove existing tray
- Remove rear wheel brace clamp
- Bolt in new tray



## DISCOVERY TD5 2.5 TDI

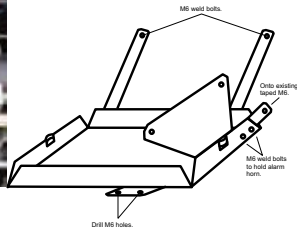

<b>PART NUMBER</b>	BTTD5
<b>BATTERY SIZE</b>	8 inch - ED4
<b>APPROX. FITTING TIME</b>	1 hour
<b>INCLUDED</b>	3 X MS BOLT 6 X MS NUT 2 X BODY WASHER 4 X WELD BOLTS 2 X J BOLT 1 X Special Top Mount
<b>LOCATION</b>	PSR

### FITTING INSTRUCTIONS

The cradle fits passenger side rear.

Alarm horn remounts onto tray. Isolator mounts on bracket on tray. Sit tray in position sliding long arm up under insulation behind pipes. These arms line up with existing holes (diesel only) use weld bolts. On the V8 these holes must be drilled. Short bracket bolts on to where horn was. Two M6 holes are drilled for front bracket. Use body washers. Top mount supplied.



## DISCOVERY TD5 DUAL AIR

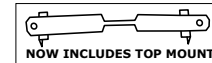
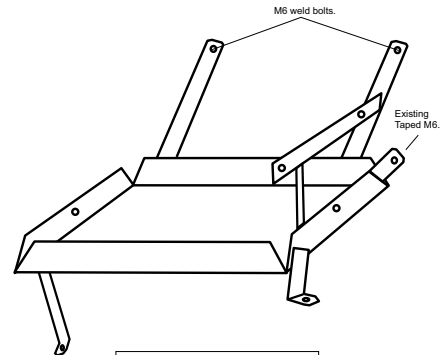

<b>PART NUMBER</b>	BTTD5AC
<b>BATTERY SIZE</b>	Narrow - ED10S
<b>APPROX. FITTING TIME</b>	1 hour
<b>INCLUDED</b>	1 X TRAY 3 X MS BOLT 4 X MS NUT 2 X BODY WASHER 4 X WELD BOLTS 1 X SPECIAL TOP MOUNT
<b>LOCATION</b>	PSR

### FITTING INSTRUCTIONS

The cradle fits passenger side rear.

Isolator mounts on bracket on tray. Sit tray in position sliding long arm up under insulation behind pipes. These arms line up with existing holes (diesel only) use weld bolts. On the V8 these holes must be drilled. Short bracket bolts on to where horn was. Use body washers. Top mount supplied.



## DISCOVERY TD6 V6 and Turbo Diesel



<b>PART NUMBER</b>	BTTD6
<b>BATTERY SIZE</b>	10 inch Optima
<b>APPROX. FITTING TIME</b>	1 hour
<b>INCLUDED</b>	1 x Tray 2 x Special M8 Nuts 1 x Universal Top mount
<b>LOCATION</b>	DSR

### FITTING INSTRUCTIONS

The cradle fits drivers side rear, beside power booster under cover.

Remove plastic cover from power booster / ABS unit. Remove 2 x 12mm Hex head nuts from centre of base, place tray into position, mark where flutes require grinding down remove tray and grind down flutes (shown in first image) this enables tray to fit comfortably. Secure tray in position using 2 x M8 nuts, supplied, shown in second image. Place battery onto tray and secure with top mount. (Pic 3) Mount isolator as shown in fourth image. Take care when replacing cover, may require cut out as shown in final



## KIA SPORTAGE

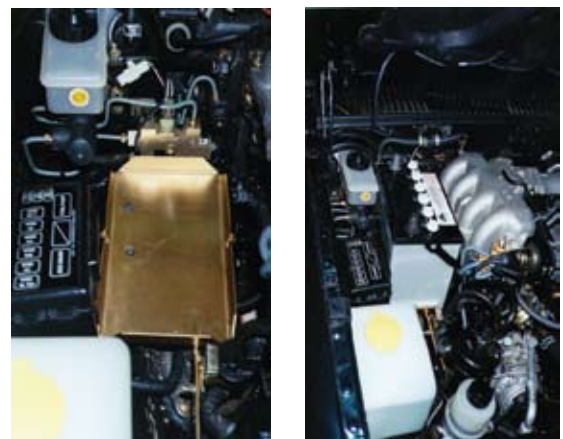

<b>PART NUMBER</b>	BTKIA
<b>BATTERY SIZE</b>	Narrow - ED10S
<b>APPROX. FITTING TIME</b>	2 hours
<b>INCLUDED</b>	3 X MS BOLT 2 X MS BOLT (on mark) 5 X MS NUT 2 X J BOLT 1 X FUEL FILTER BRKT
<b>LOCATION</b>	DSR

### FITTING INSTRUCTIONS

The cradle fits drivers side rear.

The tray faces north south. The fuel filter has to be moved back towards the fire wall. A mounting bracket is supplied for this. This cradle may not fit if the vehicle is fitted with ABS braking. The tray fits between the intake chamber and the master cylinder.



## HYUNDAI TERRACAN V6 PETROL DIESEL



<b>PART NUMBER</b>
BTHT05
<b>BATTERY SIZE</b>
10 Inch - ED50
<b>APPROX. FITTING TIME</b>
2 hours
<b>INCLUDED</b>
1 x Tray 2 x Relay Bolt 3 x M6 Long Bolt 1 x M6 Long bolt 1 x special top mount 11 x M6 bolt 8 x M6 nuts 4 x M6 body washer
<b>LOCATION</b>
PSM

### FITTING INSTRUCTIONS

The cradle fits passenger side middle.

The cradle fits on the Passenger side of the vehicle, middle of the engine bay.  
Unbolt fuel filter assembly and fuel line retaining brackets, filter is to be moved forward. Vacuum sensor to be unbolted and relocated onto tray.

Using M6 bolts, supplied, bolt fuel filter relocation bracket under air conditioning receiver drier bracket. Mount fuel filter and stabilising arm to relocation bracket.

Remove fuse box brace from inner guard and fit tray to inner guard. With supplied bolts, washers and nuts, bolt tray to captive points then drill and bolt back left corner. Fuse box mounts to cradle once in



## ROCSTA DXL PETROL



<b>PART NUMBER</b>
BTROC
<b>BATTERY SIZE</b>
8 Inch - ED4
<b>APPROX. FITTING TIME</b>
1 hour
<b>INCLUDED</b>
1 x Tray 4 x M8 bolts 4 x Panel Washers 1 x Universal to mounts 4 x M8 Nuts
<b>LOCATION</b>
DSF

### FITTING INSTRUCTIONS

The cradle fits drivers side front.

Charcoal canister to be moved to rear of engine bay, drivers side. Sit tray into position – all mounting holes require drilling. Secure with bolts provided.



## HUMMER H3



<b>PART NUMBER</b>
BTHUM3
<b>BATTERY SIZE</b>
8 Inch - ED4
<b>APPROX. FITTING TIME</b>
2 hour
<b>INCLUDED</b>
3 x M6 Hex 2 x M6 C/Sunk 5 x M6 Washers 5 x M6 Nuts
<b>LOCATION</b>
PSR

### FITTING INSTRUCTIONS

The cradle fits passenger side rear

Remove all clips & screws from wheel arch & flare (1)  
Flare slides anti clockwise on vehicle off clips Forward (2)

Remove wheel arch & remove earth from behind battery on inner guard  
Re-locate wiring on inner guard to under computer and hard against battery.

Place in tray & nut & bolt all holes.  
Bolt isolator & fuse box to tray (Advised to run wires in firewall before.)  
Fit battery to tray using narrow top mount



## SANGYONG MUSSO 2005 DUAL CAB



<b>PART NUMBER</b>
BTMDDC
<b>BATTERY SIZE</b>
12 inch - ED5
<b>APPROX. FITTING TIME</b>
1 hour
<b>INCLUDED</b>
1 X Tray 6 X M6 BOLT 1 X M6 SOLT (for sun) 9 X M6 NUT 1 x relay pack relocation bkt 1 x Universal top mount 1 x Battery Tray end supt bkt 1 x weld bolt
<b>LOCATION</b>
PSR

### FITTING INSTRUCTIONS

The cradle fits passenger side rear.

Remove Relay pack from original mounting surface and fit drop bracket to lower relay pack under battery tray (refer to picture one).  
Position battery tray on original capture thread (circled in first picture).  
Line up side mounts on lip of fire wall, drill holes, drill out holes in battery tray base and secure all with 6mm bolts and nuts. Secure battery tray end support bracket to tray using weld bolt so battery does not rub on bolt head, secure other end of support bracket to inner guard (refer to picture two).

